

# SERIE MUEBLES ESTANTERÍA



ASESORAMIENTO  
PERSONALIZADO

INGENIERÍA  
Y PROYECTOS

SOLUCIONES  
LLAVE EN MANO

EQUIPAMIENTO  
INTEGRAL

ATENCIÓN  
AL CLIENTE



Empresa Homologada por la  
Dirección General del Patrimonio del Estado

[mobiliar@mobiliar.es](mailto:mobiliar@mobiliar.es)  
[www.mobiliar.es](http://www.mobiliar.es)  
902 365 064

# LEYENDA:

SYMBOLS:  
SYMBOLES:



Dimensiones en milímetros.  
Dimensions in millimeters.  
Dimensions en millimètres.



Altura máxima en milímetros.  
Maximum height in millimeters.  
Hauteur maximale en millimètres.



Altura mínima en milímetros.  
Minimum height in millimeters.  
Hauteur minimale en millimètres.



Peso neto en kilogramos.  
Net weight in kilograms.  
Poids net en kilogrammes.



Peso neto en gramos.  
Net weight in grams.  
Poids net en grammes.



Código de producto.  
Product Code.  
Code de produit.



Colores disponibles.  
Available colors.  
Couleurs disponibles.



No son necesarias herramientas para el montaje del producto.  
No tools required for assembly of the product.  
Aucun outil requis pour l'assemblage du produit.



Diámetro en milímetros.  
Diameter in millimeters.  
Diamètre en millimètres.



Producto adaptado para lavavasos.  
Product suitable for glasswashers.  
Produit apte pour lave-verres.



Producto adaptado para lavaplatos.  
Product suitable for dishwasher.  
Produit apte pour lave-vaisselle.



Caudal de agua en litros por minuto.  
Water flow rate in liters per minute.  
Débit d'eau en litres par minute.



Temperatura máxima en grados centígrados.  
Maximum temperature in degrees Celsius.  
Température maximale en degrés Celsius.

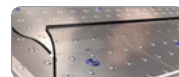
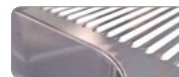

Alcance máximo.  
Maximum reach.  
Portée maximum.



Capacidad en litros.  
Capacity in liters.  
Capacité en litres.



Peso máximo soportado.  
Maximum load capacity.  
Capacité de charge maximale.



Unidades contenidas en la caja o bolsa.  
Units contained per box or bag.  
Unités contenues par boîte ou sac.



Revoluciones por minuto.  
Revolutions per minute.  
Tours par minute.



Accesorio incluido en el producto.  
Accessories included with the product.  
Accessoires inclus avec le produit.



Accesorio no incluido en el producto.  
Accessories not included with the product.  
Accessoires non inclus avec le produit.



Número de soportes.  
Number of supports.  
Nombre de supports.



Orientación de desagüe.  
Drain position.  
Position d'égouttoir.



Número de huecos.  
Number of holes.  
Nombre de trous.



Número de puertas abatibles.  
Number of hinged doors.  
Nombre de portes battantes.



Número de puertas corredera.  
Number of sliding doors.  
Nombre de portes coulissantes.



Tipo de conexión eléctrica.  
Type of electrical connection.  
Type de connexion électrique.



Producto muy pesado.  
Very heavy product.  
Produit très lourd.



Normativa internacional Gastronorm.  
Gastronorm international standards.  
Norme internationale Gastronorm.



Producto adaptado en altura para cocinas serie snack o modular.  
Product height adapted to modular or snack bar kitchens.  
Hauteur du produit adapté aux cuisines modulaires ou de restauration rapide.



Preste especial atención.  
Pay special attention.  
Prêtez particulière attention.



Ampliar información en la página.  
More information on page.  
Plus d'informations à la page.



## Optimize your space with this innovative work station

Imagine GN is a new tool thought to optimize your work room. This innovative system employs a Cantilever design that eliminates the front supports, increasing up to a 40% the useful surface within the work area.

It is installed easily and quickly. Based on the international dimensions GASTRONORM, it is made totally in stainless steel, with a modern and unique design.

Imagine GN can be used to stock in dry areas as well as in places with wet atmosphere, industrial kitchens, food preparation rooms, laboratories, clinics, garages, petrol stations, etc.

With the Imagine GN modular solutions you can easily and quickly design your working area meeting at the same time your needs of change.



Puede regular la altura (cada 140 mm.) y la inclinación de los estantes sin usar herramientas. Shelves height (every 140 mm.) and lean can be adjusted without using any tool. Vous pouvez régler l' hauteur (tous 140 mm.) et l' inclination des étagères sans utiliser des outils.

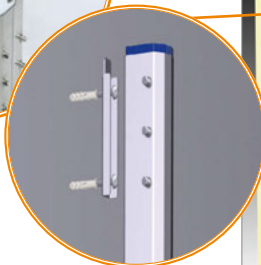

## Optimize your space with this innovative work station.

Imagine GN is a new tool, thought to optimize your work room. This innovative system employs a Cantilever design that eliminates the front supports, increasing up to a 40% the useful surface within the work area.

You can mount it easily and quickly. Based on the international dimensions GASTRONORM, it is made totally in stainless steel, with a modern and unique design.

Imagine GN can be used to stock in dry areas as well as in places with wet atmosphere, industrial kitchens, food preparation rooms, laboratories, clinics, garages, petrol stations, etc.

With the Imagine GN modular solutions you can easily and quickly design your working area meeting at the same time your needs of change.

Now with Imagine GN you will be able to re-design your work area whenever it is necessary.

### LAS NECESIDADES CAMBIAN

Needs change  
Les besoins changent



Detalle de fijación a pared. Wall fixing detail. Détails de fixation murale.

## Now with Imagine GN you can re-design your work area whenever it is necessary.

Imagine GN Optimisez votre espace avec cette nouvelle station de travail.

Imagine GN, c'est un nouveau outil conçu pour optimiser l'espace de travail. Cette innovateur système emploie un dessin Cantilever qu'évite des supports frontaux, et c'est ainsi qu'on augmente la surface utile dans la zone de travail.

On l'installe facilement et rapidement. Dessinée sur les dimensions internationales Gastronorm, elle est fabriquée totalement en acier inoxydable avec une finition moderne et unique.

Imagine GN, vous pouvez l'utiliser pour le stockage tandis dans endroits secs comme dans endroits avec atmosphère humide, cuisines industrielles, salles de préparation des aliments, laboratoires, cliniques, ateliers, stations-service, etc.

Avec les solutions modulaires Imagine GN vous pouvez configurer facile et rapidement votre espace de travail en tenant en compte au même temps votre besoins d'échange.



Maintenant avec Imagine GN vous pourrez re-dessiner votre espace quand il soit nécessaire.

## Composiciones básicas sistema imagine mural suspendida

Basic combinations of the imagine hanging wall shelf system

Combinaisons basiques du système murale suspendue imagine

### A, B, C, D, E, F

Las composiciones básicas imagine cuentan con todos los elementos necesarios para su montaje individual.

They are basic structures of the wall-side system imagine GN, and they are fully equipped for their individual assembly.

Elles sont structures basiques du système mural imagine, et sont pourvues avec tous les éléments nécessaires pour son montage individuel.

### a, b, c, d, e, f

Cuentan con los elementos necesarios para prolongar las composiciones básicas imagine. Se deben pedir únicamente con ese fin, pues no podrían montarse por sí mismas al faltarles pies, soportes, cartelas, etc.

They are the necessary elements to extend the basic structures imagine. They are complementary and can only be installed together with the basic structures.

Ils sont des éléments nécessaires pour prolonger les structures basiques imagine. Ils sont complémentaires et seulement peuvent être installés conjointement avec ces structures basiques.

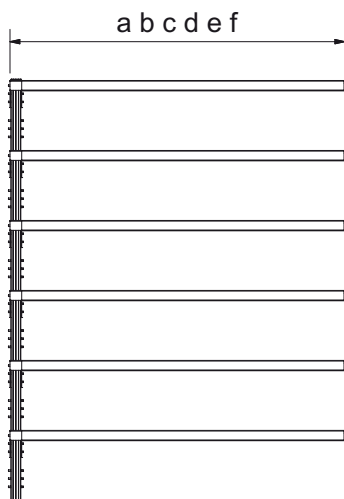
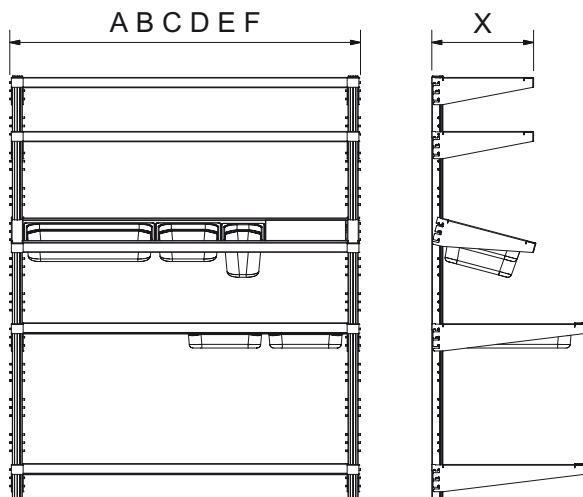

Prolongación de composiciones básicas  
Extended basic structures  
Structures basiques prolongées

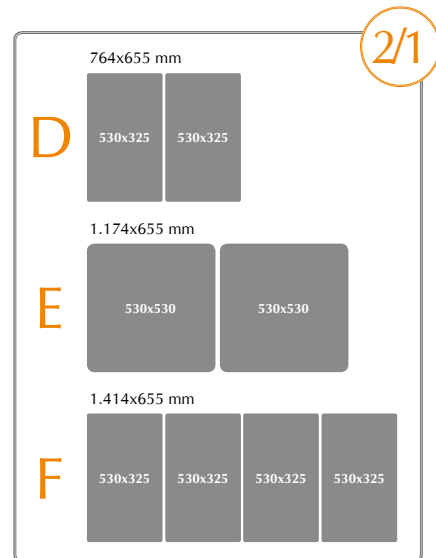
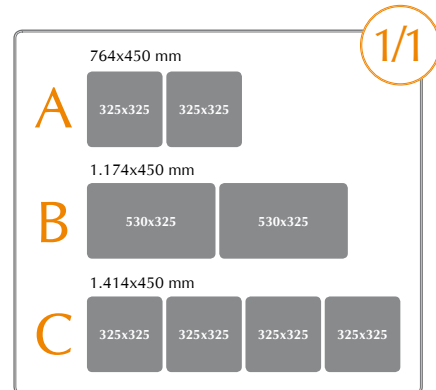

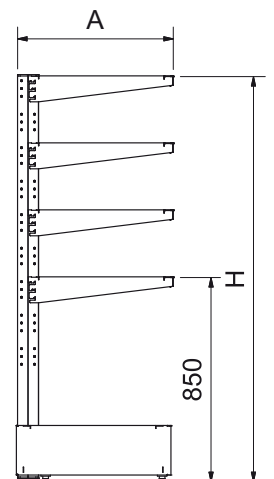
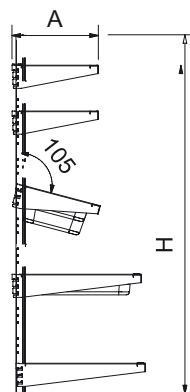
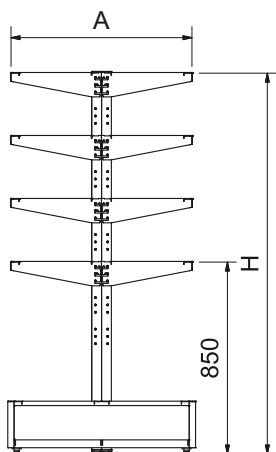
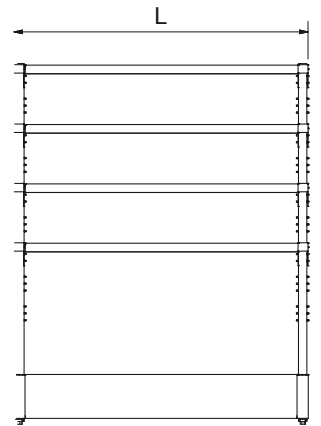
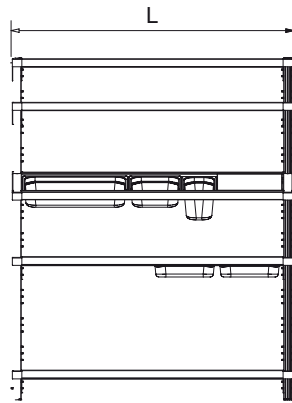
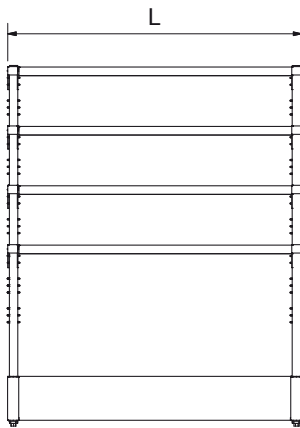



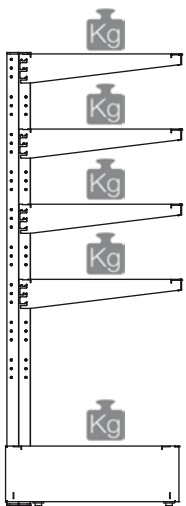
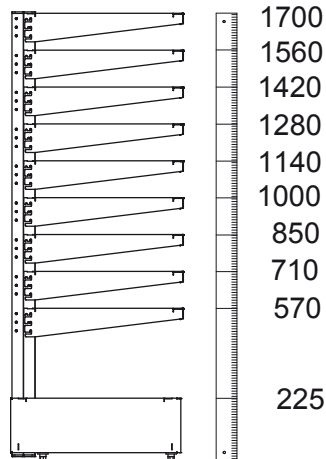
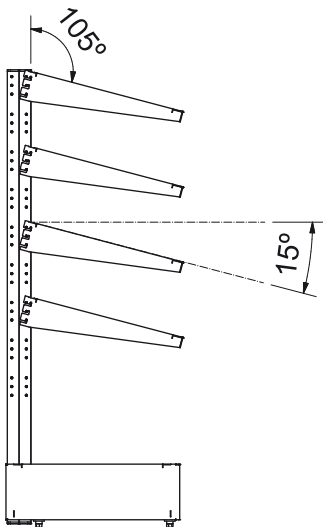

### Capacidad de estantes:

Sistema mural 10 niveles por módulo.  
 Sistema central 10 niveles dobles por módulo.

### Shelving unit capacity:

Wall-side system – 10 levels per unit.  
 Centre system – 10 double levels per unit.

### Capacité des étagères:

Système mural – 10 niveaux par module.  
 Système central – 10 niveaux doubles par module.

**Kg** = 125 Kg.

Las cargas se consideran uniformemente repartidas en la superficie del estante.  
 It is assumed that loads are evenly distributed on the shelf surface.  
 On considère que les charges sont réparties uniformément sur la surface de l'étagère.

## Composiciones básicas sistema imagine mural

Basic structures for imagine wall-side system

Compositions basiques système imagine mural

### A, B, C, D, E, F

Las composiciones básicas imagine cuentan con todos los elementos necesarios para su montaje individual.

They are basic structures of the wall-side system imagine GN, and they are fully equipped for their individual assembly.

Elles sont structures basiques du système mural imagine, et sont pourvues avec tous les éléments nécessaires pour son montage individuel.

### a, b, c, d, e, f

Cuentan con los elementos necesarios para prolongar las composiciones básicas imagine. Se deben pedir únicamente con ese fin, pues no podrían montarse por sí mismas al faltarles pies, soportes, cartelas, etc.

They are the necessary elements to extend the basic structures imagine. They are complementary and can only be installed together with the basic structures.

Ils sont des éléments nécessaires pour prolonger les structures basiques imagine. Ils sont complémentaires et seulement peuvent être installés conjointement avec ces structures basiques.

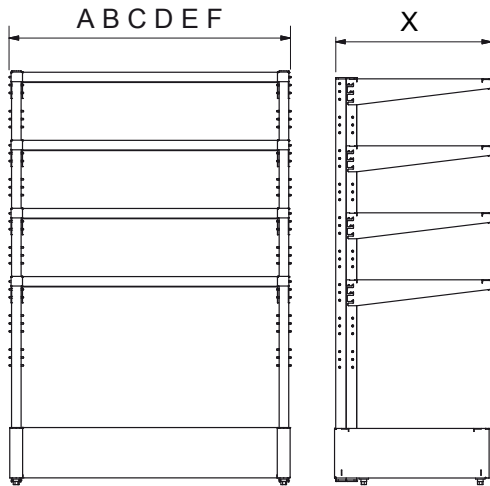

Composiciones básicas  
Basic structures  
Structures basiques

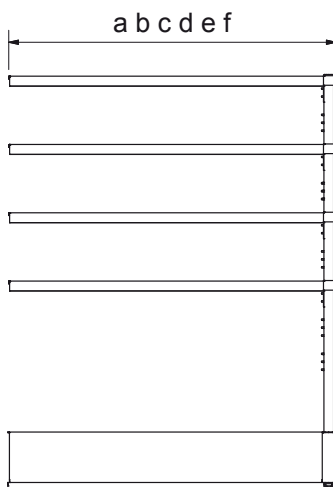

Prolongación de composiciones básicas  
Extended basic structures  
Structures basiques prolongées

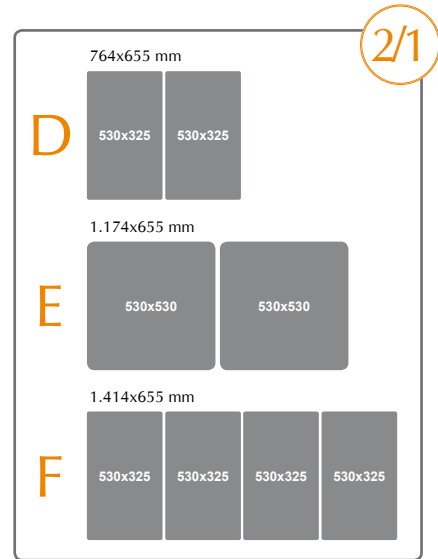
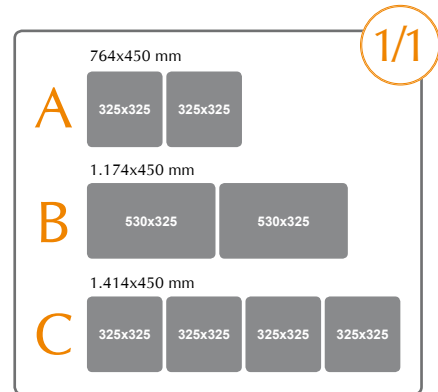

## L, M, N, P, Q, R

Las composiciones básicas imagine cuentan con todos los elementos necesarios para su montaje individual.

They are basic structures of the wall-side system imagine, and they are fully equipped for their individual assembly.

Elles sont structures basiques du système mural imagine, et sont pourvues de tous les éléments nécessaires pour son montage individuel.

## l, m, n, p, q, r

Cuentan con los elementos necesarios para prolongar las composiciones básicas imagine. Se deben pedir únicamente con ese fin, pues no podrían montarse por sí mismas al faltarles pies, soportes, cartelas, etc.

They are the necessary elements to extend the basic structures imagine GN. They are complementary and can only be installed together with the basic structures.

Ils sont des éléments nécessaires pour prolonger les structures basiques imagine GN. Ils sont complémentaires et seulement peuvent être installés conjointement avec ces structures basiques.

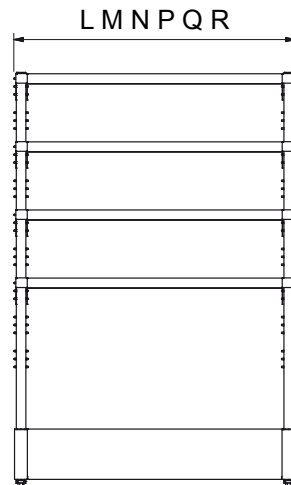
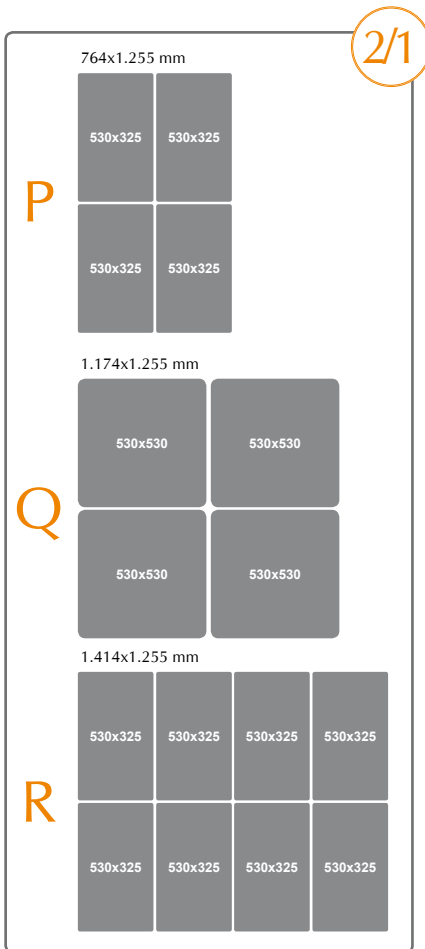
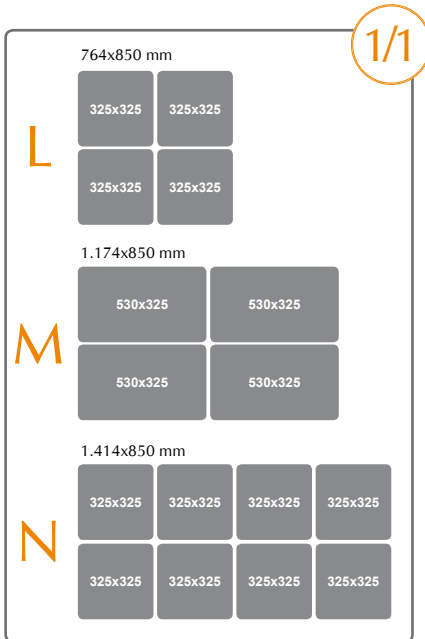

Composiciones básicas  
 Basic structures  
 Structures basiques

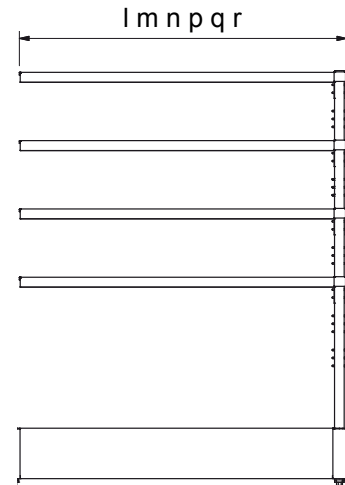

Prolongación de composiciones básicas  
 Extended basic structures  
 Structures basiques prolongées

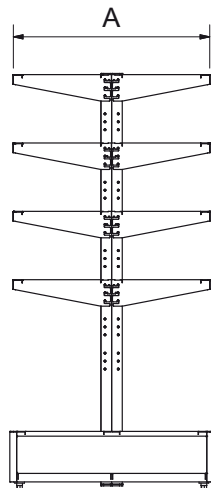



### Pies murales imagine

Wall-side legs imagine  
Pieds muraux imagine

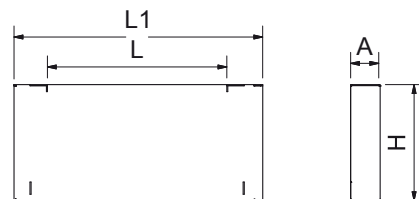

Dimensiones Dimensions Dimensions							
L	A	H	L1	Kg	Barcode	€	
325	53	210	450	3,50	013806	73,00	
530	53	210	655	5,25	013808	93,00	

### Pies centrales imagine

Centre legs imagine  
Pieds centraux imagine

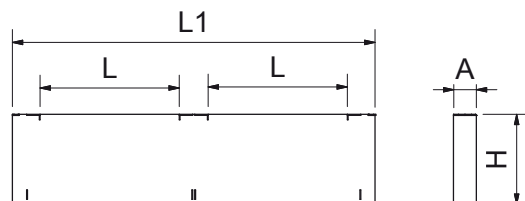

Dimensiones Dimensions Dimensions							
L	A	H	L1	Kg	Barcode	€	
325	53	210	850	6,2	013802	110,00	
530	53	210	1.260	9,2	013804	185,00	

### Largueros inferiores imagine

Lower crossbars imagine  
Montants inférieurs imagine

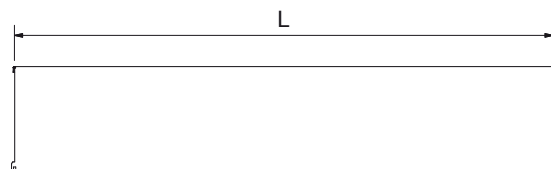

Dimensiones Dimensions Dimensions				
L	Kg	Barcode	€	
665	2,7	014252	37,00	
1.075	4,0	014254	49,00	
1.315	5,4	014256	62,00	

**Soporte imagine**  
Support imagine  
Support imagine

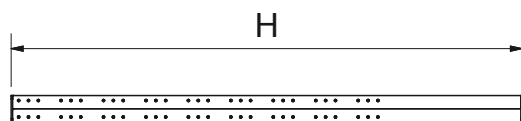

Dimensiones  
Dimensions  
Dimensions

H	Kg	013602	€
1.700	6	013602	130,00

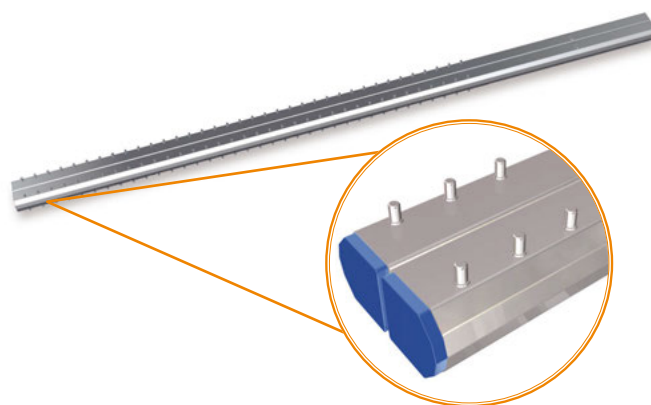

**Montante imagine suspendida**  
Support for Imagine hanging wall shelf  
Support pour Imagine murale suspendue

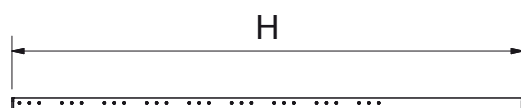

Dimensiones  
Dimensions  
Dimensions

H	Kg	013606	€
860	1,5	013606	52,00
1.700	3,0	013604	81,00

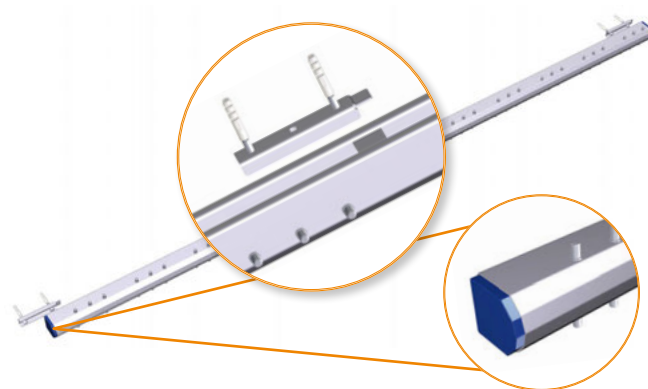

**Cartelas imagine**  
Brackets imagine  
Consoles imagine

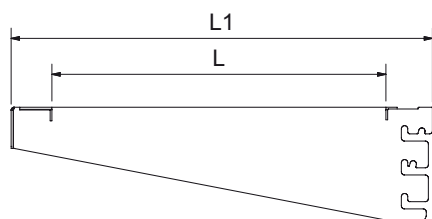

Dimensiones  
Dimensions  
Dimensions

L	L1	Kg	014002	€
325	410	1,8	014002	22,00
530	615	2,5	014004	27,00



**Largueros superiores imagine**  
Upper crossbars imagine  
Montants supérieurs imagine

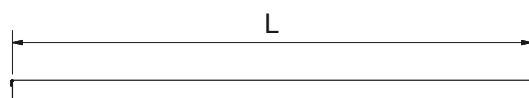

Dimensiones  
Dimensions  
Dimensions

L	Kg	014202	€
665	1,3	014202	19,00
1.075	1,9	282806	26,00
1.315	2,4	014204	32,00

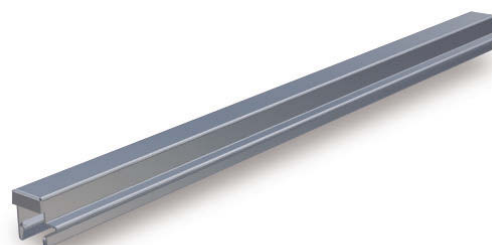

### Estantes inox imagine

Stainless steel shelves imagine

Étagères en acier inoxydable imagine

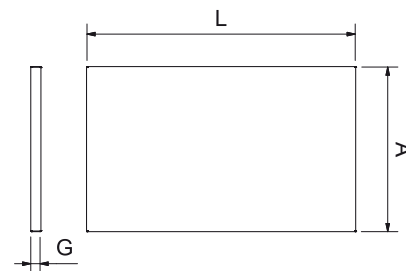
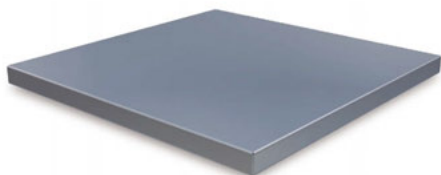

Dimensiones Dimensions Dimensions				
L	A	G	Kg	Barcode
325	325	20	1,0	013402
530	325	20	1,5	013404
530	530	20	2,0	013406

### Estantes fibra imagine

Polyethylene shelves imagine

Étagères en polyéthylène imagine

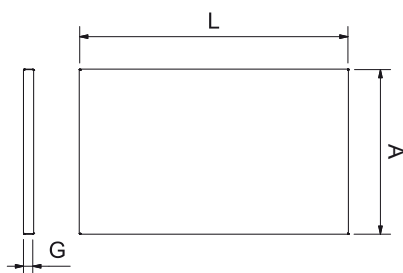
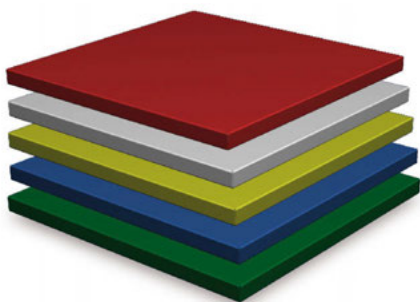

Dimensiones Dimensions Dimensions					
Color	L	A	G	Kg	Barcode
Red	325	325	20	2,12	434602
	530	325	20	3,45	434604
	530	530	20	5,62	434606
Grey	325	325	20	2,12	434610
	530	325	20	3,45	434612
	530	530	20	5,62	434614
Yellow	325	325	20	2,12	434620
	530	325	20	3,45	434622
	530	530	20	5,62	434624
Blue	325	325	20	2,12	434630
	530	325	20	3,45	434632
	530	530	20	5,62	434634
Green	325	325	20	2,12	434640
	530	325	20	3,45	434642
	530	530	20	5,62	434644

### Hacer agujero de desbarasado a estantes imagine

Imagine shelf perforation for waste chutes

Perforer étagère imagine pour évacuation de déchets

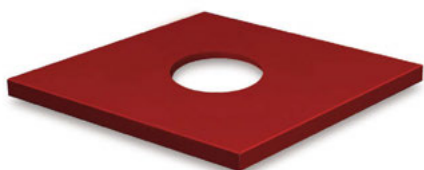
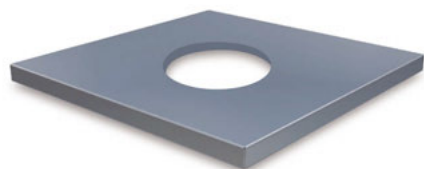

Dimensiones Dimensions Dimensions		
Color	Material	Code
White	Acero inoxidable Stainless steel Acier inoxydable	015002
Red	Fibra Fibre Fibre	434802

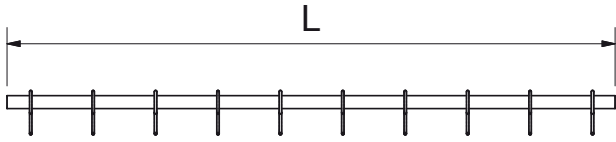

Dimensiones Dimensions Dimensions	Número de ganchos incluidos Number of hooks included Número de crochets inclus	Kg	Barcode
L			
650	10	0,30	014602
1.060	10	0,50	014604
1.300	20	0,65	014606

Dimensiones Dimensions Dimensions	H	E	D	Barcode
	60	16	3	022502



45

**Boxes modulares**  
 Modular boxes  
 Boxes modulaires

Con este sistema de boxes modulares ya puede configurar a su medida las mesas, fregaderos, estanterías, tajos, etc.

Basados en las dimensiones internacionales GASTRONORM están fabricados totalmente en acero inoxidable. Su diseño moderno y funcional permite adaptar guías, cajones, cubetas, puertas etc.

With this system of modular boxes now you can adapt to your needs tables, sink units, shelving units, chopping blocks, etc.

Based in the international dimensions GASTRONORM, it is made totally from stainless steel. Its innovative and functional design allows the fitting of elements such as guides, drawers, pans, doors, etc.

Avec le système de boxes modulaires maintenant vous pouvez adapter à vos besoins tables, éviers, étagères, billots, etc.

Ce système, basé dans les mesures internationales GASTRONORM, est fabriqué totalement en acier inoxydable. Sa conception moderne et fonctionnelle permet d'adapter guides, tiroirs, bacs, portes, etc.

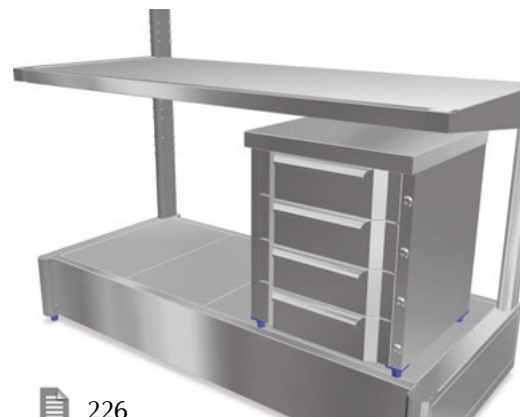

226

**Cajón acoplado a estante 2/1 imagine**  
 Drawer assembled to shelf 2/1 imagine  
 Tiroir assemblé à étagère 2/1 imagine

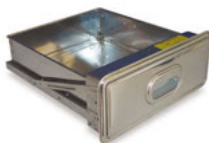

085450



085452

## Porta-precios imagine

Price-holder imagine  
Porte prix imagine



Se acoplan con facilidad a los largueros superiores.  
Easy to assemble to the upper crossbars.  
Facilité d'assemblage aux montants supérieurs.

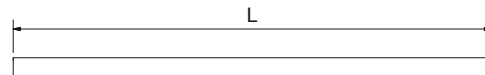

Dimensiones Dimensions Dimensions		
L	Gr	Barcode
650	65	415250
1.060	105	415252
1.300	130	415254

## Útil de montaje imagine

Assembly tool imagine  
Outil de montage imagine

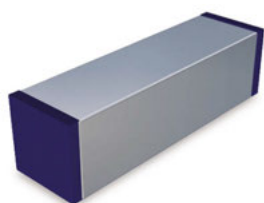

Facilita considerablemente el montaje.  
It makes the assembly greatly easier.  
Il facilite l'assemblage.

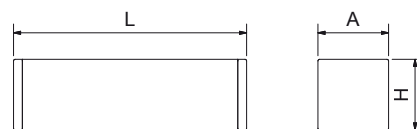

Dimensiones Dimensions Dimensions				
L	A	H	Gr	Barcode
125	40	40	180	014402

## Peto transparente imagine

Transparent front panel for imagine  
Panneau frontal transparent pour imagine

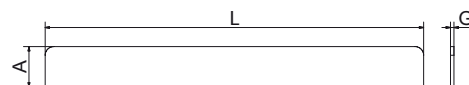

Dimensiones Dimensions Dimensions				
L	A	G	Gr	Barcode
655	70	6	175	014802
1.065	70	6	250	014804
1.305	70	6	375	014806

## Pinzas porta-precios imagine

Price-holder clamp for imagine  
Pince à dessin porte-prix pour imagine



Height	Gr	Barcode
100	40	413402
105	40	413406
150	48	413404
190	42	413408
145	38	413410

**Mesa central de emplacado imagine**  
 Preparing and serving centre table imagine  
 Table centrale pour préparation et service imagine

317 

**Cubetas Gastronorm.**  
 Gastronorm trays.  
 Bacs gastronorm.

 €    
 434602 17,00 18



**Estante en fibra de polietileno con agujero.**  
 Perforated polyethylene shelves.  
 Étagères perforées en polyéthylène.

 €    
 486004 247,00 282

**Contenedor inoxidable con tapa.**  
 Stainless steel dustbin.  
 Poubelle inox.

89 

**Cuchillería profesional.**  
 Professional cutlery.  
 Coutellerie professionnelle.

 Includo / Included / Inclus  
 Opcional / Optional / Optionnel



**Dimensiones**  
 Dimensions  
 Dimensions

L	A	H	Kg	
764	1.050	1.700	61	CE-A
1.174	1.050	1.700	71	CE-B
1.414	1.050	1.700	82	CE-C

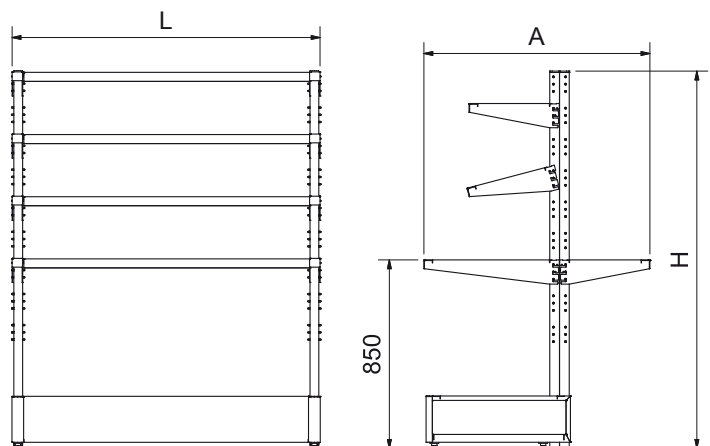



## Mesa mural con estantes sobremesa serie imagine

Wall-side table with superior shelves series imagine

Table murale avec étagères sur table modèle imagine



014602 19

Kit para colgar utensilios.  
Tool-holder kit.  
Kit pour suspendre outils.



448616 115,00 259

Guante de malla de acero inoxidable Expert.  
Expert stainless steel mesh glove.  
Gant en maille d'acier inoxydable Expert.



454802 67,00 162

Escurridor de platos y vasos de 510 mm.  
Plate and glasses 510 mm rack.  
Égouttoir pour assiettes et verres 510 mm.



124



Tijeras pescadero.  
Fish scissors.  
Ciseaux à poisson.



434602 18

Estante en fibra de polietileno con agujero.  
Perforated polyethylene shelves.  
Étagères perforés en polyéthylène.



89



Cuchillería profesional.  
Professional cutlery.  
Coutellerie professionnelle.



317



Cubetas Gastronorm.  
Gastronorm trays.  
Bacs gastronorm.



486004 247,00 282

Contenedor inoxidable con tapa.  
Stainless steel dustbin.  
Poubelle inoxydable.



085452 271,00 19

Cajón acoplado.  
Coupled drawer.  
Tiroir accouplé.

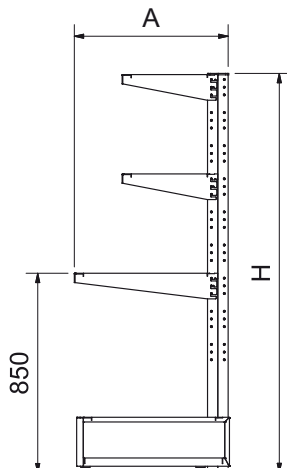
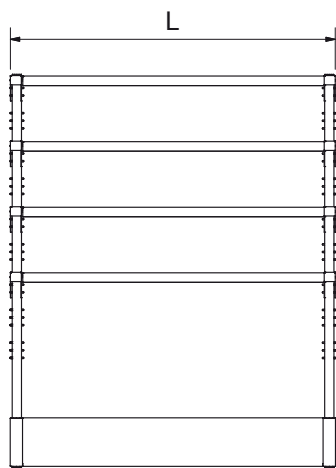

Includido / Included / Inclus

Opcional / Optional / Optionnel

Dimensiones  
Dimensions  
Dimensions

L A H Kg

764 655 1.700 55 MES-A

1.174 655 1.700 64 MES-B

1.414 655 1.700 73 MES-C

## Mesa central con estantes de sobremesa sistema imagine

Centre table with tabletop shelves imagine system

Table centrale avec étagères à poser sur table système imagine



454802 67,00 162

Escurridor de platos y vasos de 510 mm.  
Plate and glasses 510 mm rack.  
Égouttoir pour assiettes et verres 510 mm.



081802 30,00 332

Porta notas mural acoplado.  
Wall mounted note holder.  
Porte notes mural.



434442 120,00 88

Mortero de fibra.  
Mortar.  
Mortier.



080202 73,00 293

Dispensador de bobinas para envolver de 350 mm.  
Dispenser rolls of wrapping material.  
Dévidoir de rouleaux pour protéger les aliments.



434440 43,00 87

Rodillo de fibra.  
Rolling pin.  
Rouleau.

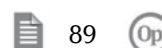

89

Cuchillería profesional.  
Professional cutlery.  
Coutellerie professionnelle.



486004 247,00 282

Contenedor inoxidable con tapa.  
Stainless steel dustbin.  
Poubelle inoxydable.



431608 24,00 76

Fibra estándar azul de 500x300x20 mm.  
Blue standard fibre 500x300x20 mm.  
Fibre standard bleue 500x300x20 mm.



041202 125,00 133

Portacuchillos con doble alojamiento de sobremesa.  
Plated knife holder for mounting.  
Porte-couteaux plaqué pour adosser.



- Includo / Included / Inclus
- Opcional / Optional / Optionnel

### Dimensiones Dimensions Dimensions

L	A	H	Kg	
764	1.255	1.700	77	
1.174	1.255	1.700	95	
1.414	1.255	1.700	115	

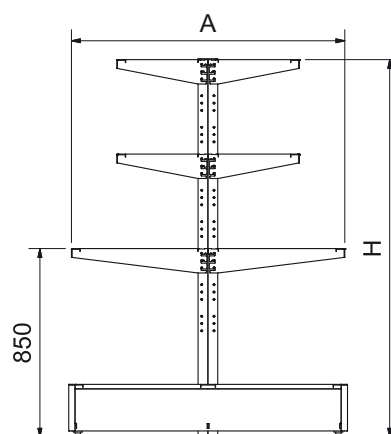
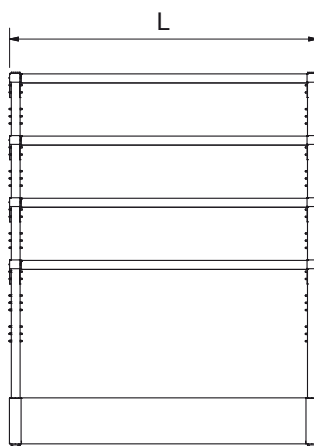

# Estanterías modulares

## Modular shelving

## Rayonnages modulaires

### Características de fabricación:

Construidas totalmente en acero inoxidable, acabado satinado.  
Doble pliegue con pestaña aplastada en los estantes, para evitar cortes y ganar resistencia.  
Fácil montaje.  
Gran diversidad de medidas para una máxima adaptación a su lugar de colocación.  
Alturas disponibles desde 850 mm, para su utilización como mesas de apoyo, carros, etc., hasta 2950 mm para el mejor aprovechamiento del espacio.  
Dos espesores de chapa disponibles y con la opción de poder solicitarlas con refuerzos soldados en su base, ver página 27.  
Se puede regular la altura entre estante y estante cada 100 mm, con posibilidad de poner un estante a ras de suelo.  
Pies regulables para una mayor estabilidad en cualquier suelo.  
Posibilidad de colocación de ruedas, ver página 353.  
Opcionalmente se pueden suministrar con kit de pletinas. Ver página 27.

### Manufacturing characteristics:

Made totally in stainless steel shiny finished. Double fold with crushed fringe in shelves, to avoid any bad cut and to increase the resistance.  
Easy mounting.  
Great diversity of measures to allow a maximum fitting to the mounting room.  
Available heights from 850 mm for its usage as auxiliar tables, chars, etc. up to 2950 mm for the best use of the room.  
Sheet thick available in two measures with the option of order them with reinforcements fixed at its base. See page 27.  
Height adjustment every 100 mm, with the possibility of mounting one shelf at the ground level.  
Adjustable feet to allow a higher stability on any floor.  
Possibility of fixing wheels. See page 353.  
They can be supplied optionally with plates and hooks. See page 27.

### Caractéristiques de fabrication:

Construit totalement en acier inoxydable finition satinée.  
Double pli avec rebord aplati pour éviter des coupures et gagner en résistance.  
Facilité de montage.  
Grand diversité de mesures pour une maxime adaptation a l'endroit de installation.  
Hauteur disponibles depuis 850 mm pour l'utilisation comme tables auxiliaires, chariots, etc, jusqu'à 2950 mm pour le mieux profit de l'espace.  
Deux épaisseurs de tôle disponibles avec l'option de les solliciter avec renforcements soudés dans sa base. Voir page 27.  
Hauteur réglable tous les 100 mm, avec la possibilité de monter une étagère au niveau du sol.  
Pieds réglables pour une plus grande stabilité dans n'importe quel sol.  
Possibilité de montage de rouelles. Voir page 353.  
Optionnellement elles peuvent être fournies avec un kit de platines et crochets. Voir page 27.

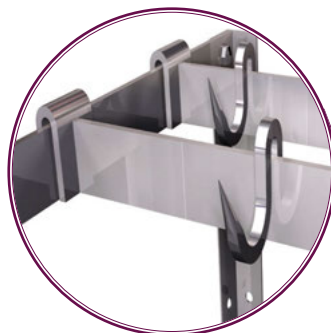

Detalle de kit de pletinas acoplado a estantería.  
Detail of plates set coupled in shelving.  
Détail de kit de pletines accouplé dans le rayonnage.

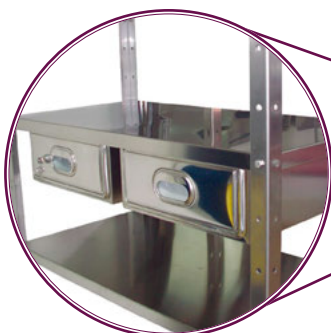

Posibilidad de acoplar cajones a estantes.  
Drawer coupled possibility.  
Possibilité de tiroir accouplé.

349

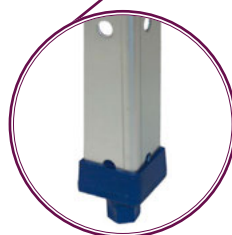

Detalle del pie del soporte de estantería.  
Detail of shelving support base.  
Détail du pied du support de rayonnage.

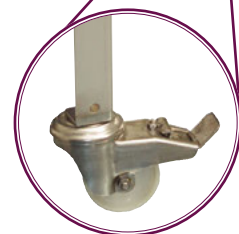

Posibilidad de acoplar ruedas a soportes de estantería.  
Castor fixed to shelving supports possibility.  
Possibilité de rouelle accouplée dans supports de rayonnage.



## Cuadro comparativo de estanterías modulares con estantes lisos de 0.8 mm

Comparative table of modular shelving with non-perforated 0.8 mm shelves  
Tableau comparatif de rayonnages modulaires avec étagères lisses de 0,8 mm

Dimensiones Dimensions Dimensions			Número de estantes Number of shelves Número d'étagères			
L	A	H	3	4	5	6
800	300	1.750				
1.000	300	1.750				
1.200	300	1.750				
1.400	300	1.750				
800	400	1.750				
1.000	400	1.750				
1.200	400	1.750				
1.400	400	1.750				
800	500	1.750				
1.000	500	1.750				
1.200	500	1.750				
1.400	500	1.750				
800	600	1.750				
1.000	600	1.750				
1.200	600	1.750				
1.400	600	1.750				

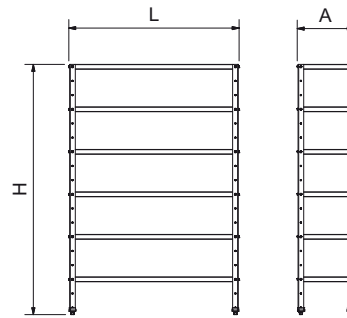

Estos precios incluyen estantes, soportes, tornillos y tuercas.

Shelves, shelving supports, nuts and bolts included in these prices.

Etagères, supports de rayonnage et vis à écrou compris dans ces prix.

## Cuadro comparativo de estanterías modulares con estantes lisos de 1.5 mm

Comparative table of modular shelving with non-perforated 1.5 mm shelves  
Tableau comparatif de rayonnages modulaires avec étagères lisses de 1.5 mm

Dimensiones Dimensions Dimensions			Número de estantes Number of shelves Número d'étagères			
L	A	H	3	4	5	6
800	300	1.750				
1.000	300	1.750				
1.200	300	1.750				
1.400	300	1.750				
800	400	1.750				
1.000	400	1.750				
1.200	400	1.750				
1.400	400	1.750				
800	500	1.750				
1.000	500	1.750				
1.200	500	1.750				
1.400	500	1.750				
800	600	1.750				
1.000	600	1.750				
1.200	600	1.750				
1.400	600	1.750				

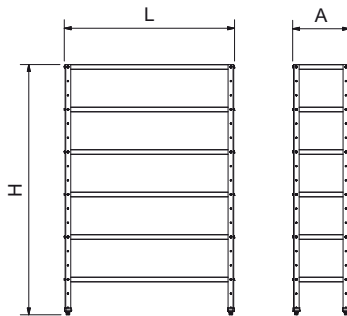

Estos precios incluyen estantes, soportes, tornillos y tuercas.

Shelves, shelving supports, nuts and bolts included in these prices.

Etagères, supports de rayonnage et vis à écrou compris dans ces prix.

## Estantes lisos para estanterías modulares

Flat shelves for modular shelving

Etagères lisses pour rayonnages modulaires

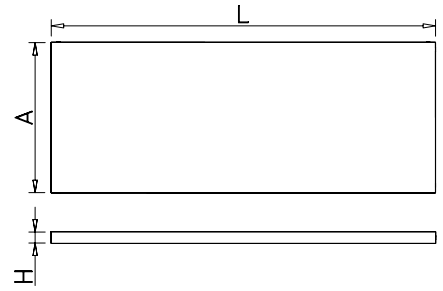

Dimensiones Dimensions			Estantes de 0,8 mm 0,8 mm shelves Étagères 0,8 mm		Estantes de 1,5 mm 1,5 mm shelves Étagères 1,5 mm	
L	A	H	Kg	Barcode	Kg	Barcode
800	300	35	2,20	010202	4,16	010402
1.000	300	35	2,78	010204	5,14	010404
1.200	300	35	3,24	010206	6,02	010406
1.400	300	35	3,76	010208	7,02	010408
800	400	35	2,76	010210	5,32	010410
1.000	400	35	3,40	010212	6,30	010412
1.200	400	35	4,04	010214	7,71	010414
1.400	400	35	4,76	010216	9,00	010416
800	500	35	3,36	010218	6,16	010418
1.000	500	35	4,14	010220	7,68	010420
1.200	500	35	4,90	010222	9,12	010422
1.400	500	35	5,56	010224	10,58	010424
800	600	35	3,86	010226	7,30	010426
1.000	600	35	4,94	010228	8,98	010428
1.200	600	35	5,60	010230	10,70	010430
1.400	600	35	6,50	010232	12,34	010432

## Soportes de estantería

Shelving supports

Supports de rayonnage



Inc

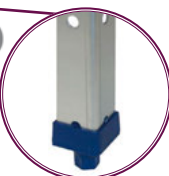

### Características:

Espesor del acero 2 mm.

Admiten estante a nivel del suelo.

Separación entre taladros de 100 mm.

### Characteristics:

Stainless steel thickness 2 mm.

Shelf allowed at ground level.

Holes are 100 mm apart.

### Caractéristiques:

Acier inoxydable épaisseur 2 mm.

Étagère admise au niveau du sol.

Ecart des trous tous les 100 mm.

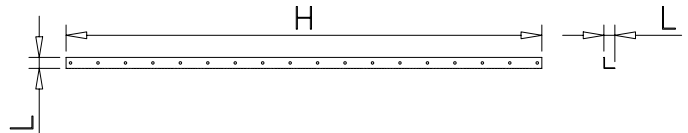

Dimensiones  
Dimensions

H L Kg Barcode

850 40x40 1,05 011002

1.050 40x40 1,24 011004

1.450 40x40 1,62 011006

1.750 40x40 2,02 011008

2.050 40x40 2,38 011010

2.350 40x40 2,58 011012

2.950 40x40 2,69 011014

## Refuerzos soldados a estantes

Welded reinforcements for shelves  
Renforts soudés aux étagères

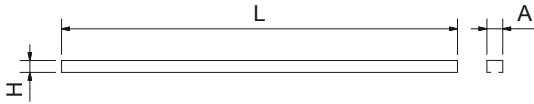

Dimensiones Dimensions Dimensions					
L	A	H	Kg	Barcode	
800	40	30	1,02	011202	
1.000	40	30	1,18	011204	
1.200	40	30	1,41	011206	
1.400	40	30	1,65	011208	

**Características:**  
Aumentan la capacidad de carga. Ver página 28

**Characteristics:**  
Increase load-capacity. See page 28

**Caractéristiques:**  
Sert à améliorer la capacité de chargement. Voir page 28



## Tornillos y tuercas para estantes

Nut and bolt for shelves  
Vis à écrou pour étagères

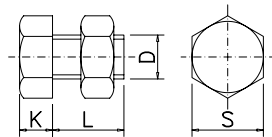

Dimensiones Dimensions Dimensions						
	D	L	S	K	Gr	€
<b>Tornillo</b> Bolt Vis	M8	12	13	5,3	7,00	421012
<b>Tornillo</b> Bolt Vis	M8	25	13	5,3	11,00	421016
<b>Tuerca</b> Nut Écrou	M8		13	5,3	4,00	421056

**Tornillo para unión de estanterías.**  
Screw for shelving units union.  
Vis pour union d'étagères.

**8 tornillos y tuercas por estante.**  
8 nut and bolt for shelf.  
8 vis à écrou pour étagère.

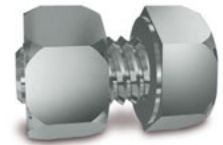

## Kit de pletinas para estanterías

Plate kit for shelves  
Kit de platines pour rayonnages

Dimensiones Dimensions Dimensions		Kit 1 Pletina One plate kit Kit de 1 platine	Pletina Opcional Optional plate Platine en option
L	A	Barcode	€
800	300	012802	<b>142,00</b>
	400	012810	<b>152,00</b>
	500	012818	<b>162,00</b>
	600	012826	<b>172,00</b>
1.000	300	012804	<b>152,00</b>
	400	012812	<b>162,00</b>
	500	012820	<b>172,00</b>
	600	012828	<b>182,00</b>
1.200	300	012806	<b>162,00</b>
	400	012814	<b>172,00</b>
	500	012822	<b>182,00</b>
	600	012830	<b>191,00</b>
1.400	300	012808	<b>172,00</b>
	400	012816	<b>182,00</b>
	500	012824	<b>192,00</b>
	600	012832	<b>201,00</b>

### Dotación de cada kit de pletinas:

Una pletina de la medida del largo de la estantería, con una "U" soldada a cada extremo. Dos pletinas de la medida del ancho de la estantería preparadas para atornillar a los soportes. Tornillería.

**Each plate kit consists of:**  
One plate of the same length as the shelves with a U-shaped bracket welded to either end. Two plates of the same width as the shelves ready to be bolted to the supports. Nuts and bolts.

**Dotation de chaque kit de platines:**  
Une platine mesurant la largeur de l'étagère avec deux "U" soudés à chaque extrémité. Deux platines mesurant la largeur de l'étagère conçues pour être vissées aux supports. Visserie.





## Resistencia de carga por estante de 0.8 mm de espesor

Load strength per 0.8 mm thick shelf

Résistance de charge par étagère de 0,8 mm d'épaisseur



Las cargas se consideran uniformemente repartidas en la superficie del estante.

It is assumed that loads are evenly distributed on the shelf surface.

On considère que les charges sont réparties uniformément sur la surface de l'étagère.

Resistencia de carga en Kgs Kgs load strength Résistance de charge Kgs				
Dimensiones Dimensions Dimensions	Sin refuerzos Without reinforcement Sans renforts	1 refuerzo 1 reinforcement 1 Renforts	2 refuerzos 2 reinforcement 2 Renforts	3 refuerzos 3 reinforcement 3 Renforts
800x300	225	275	325	
1.000x300	175	225	275	
1.200x300	125	150	200	
1.400x300	100	125	175	
800x400	200	250	300	350
1.000x400	150	200	250	300
1.200x400	100	125	175	225
1.400x400	75	100	150	200
800x500	200	250	300	350
1.000x500	150	200	250	300
1.200x500	100	125	175	225
1.400x500	75	100	150	200
800x600	175	225	275	325
1.000x600	125	175	225	275
1.200x600	75	100	150	200
1.400x600	50	75	125	175

## Resistencia de carga por estante de 1.5 mm de espesor

Load strength per 1,5 mm thick shelf

Résistance de charge par étagère par 1,5 mm d'épaisseur



Las cargas se consideran uniformemente repartidas en la superficie del estante.

It is assumed that loads are evenly distributed on the shelf surface.

On considère que les charges sont réparties uniformément sur la surface de l'étagère.

Resistencia de carga en Kgs Kgs load strength Résistance de charge Kgs				
Dimensiones Dimensions Dimensions	Sin refuerzos Without reinforcement Sans renforts	1 refuerzo 1 reinforcement 1 Renforts	2 refuerzos 2 reinforcement 2 Renforts	3 refuerzos 3 reinforcement 3 Renforts
800x300	300	350	400	
1000x300	250	300	375	
1200x300	150	200	275	
1400x300	125	175	225	
800x400	275	325	375	475
1000x400	225	275	350	450
1200x400	125	175	250	350
1400x400	100	150	200	300
800x500	275	325	375	475
1000x500	225	275	350	450
1200x500	125	175	250	350
1400x500	100	150	200	300
800x600	250	300	350	450
1000x600	200	250	325	425
1200x600	100	150	225	325
1400x600	75	125	175	275

## Soporte de sobremesa y mural porta-cubetas Gastronorm

Worktop and wall fixed Gastronorm trays holder  
Support sur table et mural porte-cuveaux Gastronorm



### Características:

Fabricado en acero inoxidable.

Para uso de sobremesa o fijación mural (incluye tornillos para su fijación a la pared).

Admite cubetas de hasta 200 mm de profundidad.

Empleando los perfiles divisorios podrá ubicar numerosas combinaciones según sus necesidades.

Posibilidad de regular la inclinación.

No incluye las cubetas ni los perfiles.

Cubetas y tapas. Ver página 317.

Perfiles divisorios. Ver página 323.

Asa universal para cubetas. Ver página 320.

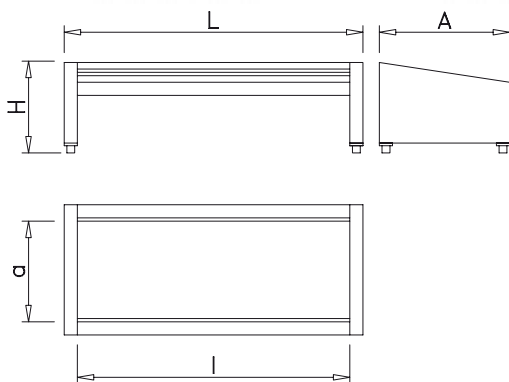

### Dimensiones

Dimensions  
Dimensions

L	A	H	i	a	Kg	Barcode
740	390	275	655	325	6,0	082803
1.150	390	275	1.065	325	7,5	082804
1.390	390	275	1.305	325	8,5	082806

### Characteristics:

Manufactured in stainless Steel.

For worktop or wall mounted use (screws included).

It can lodge Gastronorm containers up to 200 mm depth.

You can carry out numerous combinations depending on your needs by using the dividing sections.

Possibility of lean adjustment.

Gastronorm containers and dividing sections not included.

Lids and containers, see page 317.

Dividing sections, see page 323.

Standard handle for Gastronorm containers, see page 320.

### Caractéristiques:

Fabriqu  en acier inoxydable.

Il est con u   poser sur table ou   accrocher au mur.

Il peut loger des bacs Gastronorm jusqu'  200 mm de profondeur.

Vous pouvez r aliser des combinaisons nombreuses selon vos besoins en utilisant les sections de s paration

Possibilit  de r gler l'inclinaison.

Bacs GN et des sections de s paration n'ont pas inclus.

Couvercles et les r cipients, voir page 317.

Sections de s paration, voir page 323.

Poign e standard pour r cipients Gastronorm, voir page 320.

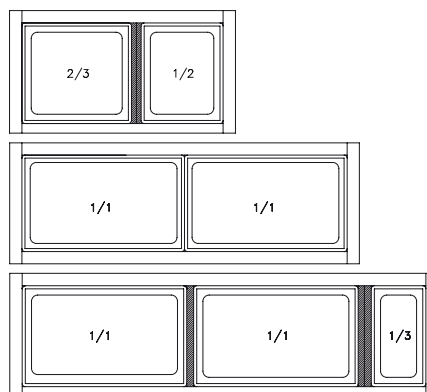

## Estantes murales cartelas modelo compacto

Fixed wall shelves

Etagères murales modèle compact



### Characteristics:

The main characteristic of these shelves is that they are made in one only piece, with all their angles welded, back fringe as well as double fold to avoid any burrs or dirtiness deposits.

These shelves generally use our bolt code 421034 and our plug code 409824. See page 65.

### Caractéristiques:

La principale caractéristique de ces étagères est qu'elles sont fabriquées d'une seule pièce, avec tous ses arêtes soudées, dossierer postérieur, ainsi que double pli, pour éviter des bavures et l'accumulation du saleté.

Généralement, cet étagères utilisent notre vis code 421034 et notre cheville code 409824. Voir page 65.



**Tornillos y tacos no incluidos en el precio.**

Bolts and plugs not included in the price.

Les vises et les chevilles ne sont pas inclus dans le prix.

## Estantes murales de tubo

Tube wall shelves

Etagères murales en tube



These shelves generally use our bolt code 421034 and our plug code 409824. See page 65.

Généralement, cet étagères utilisent notre vis code 421034 et notre cheville code 409824. Voir page 65.



**Tornillos y tacos no incluidos en el precio.**

Bolts and plugs not included in the price.

Les vises et les chevilles ne sont pas inclus dans le prix.

## Estante mural especial microondas

Wall shelf - specially for microwaves

Etagère murale spéciale micro - ondes

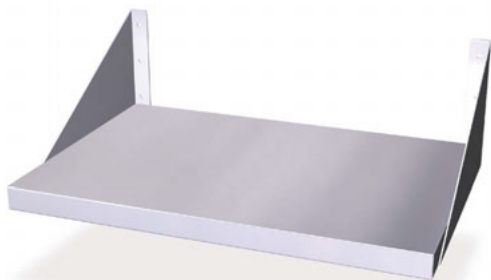

**Tornillos y tacos no incluidos en el precio.**

Bolts and plugs not included in the price.

Les vises et les chevilles ne sont pas inclus dans le prix.

### Características:

La principal característica de estos estantes es su construcción en una sola pieza, con todas sus aristas soldadas y peto posterior, así como doble pliegue aplastado para evitar rebabas y depósitos de suciedad.

Estos estantes se suelen atornillar a la pared con nuestro tornillo cód. 421034 y con el taco cód. 409824. Ver página 65.

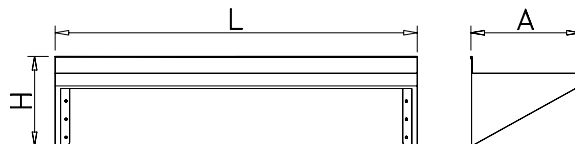

Dimensiones  
Dimensions  
Dimensions

L	A	H	Kg	Barcode
1.000	300	245	3,50	011402
1.250	300	245	4,10	011404
1.500	300	245	4,70	011406
1.000	400	245	4,28	011408
1.250	400	245	5,04	011410
1.500	400	245	5,80	011412
1.000	500	245	5,08	011414
1.250	500	245	6,00	011416
1.500	500	245	6,70	011418

Estos estantes se suelen atornillar a la pared con nuestro tornillo cód. 421034 y con el taco cód. 409824. Ver página 65.

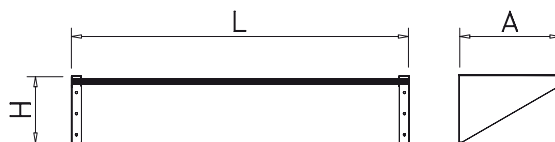

Dimensiones  
Dimensions  
Dimensions

L	A	H	Kg	Barcode
750	300	200	4,00	011902
1.000	300	200	4,11	011904
750	400	200	4,80	011906
1.000	400	200	5,65	011908

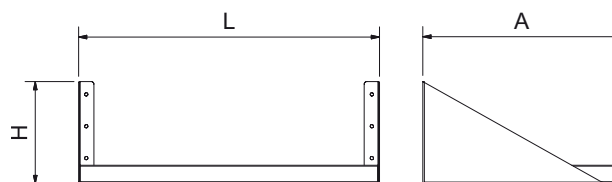

Dimensiones  
Dimensions  
Dimensions

L	A	H	Kg	Barcode
590	388	200	3,00	015202



Basados en las medidas internacionales GASTRONORM. Podrá intercambiar los estantes por recipientes, parrillas y fibras GN.

Based in the international standard GASTRONORM. You can replace the shelves for Gastronorm containers, grills and GN fibres.

Basé dans le standard international GASTRONORM. Vous pouvez remplacer les étagères pour les bacs, grilles GN et plaques GN.

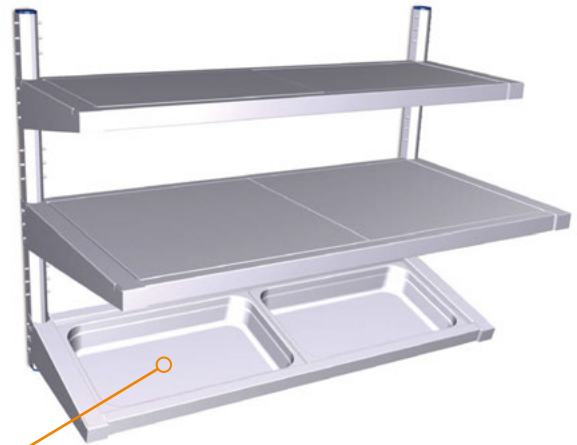

**Cubetas Gastronorm.**  
Gastronorm trays.  
Cuveau gastronorm.

**Configuraciones:**  
Range of configurations:  
Gamme de configurations:

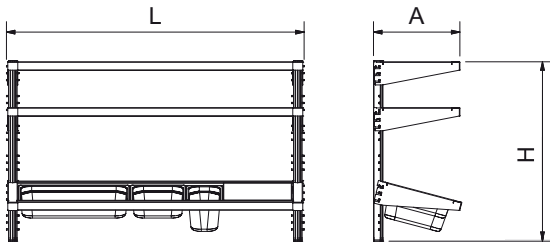
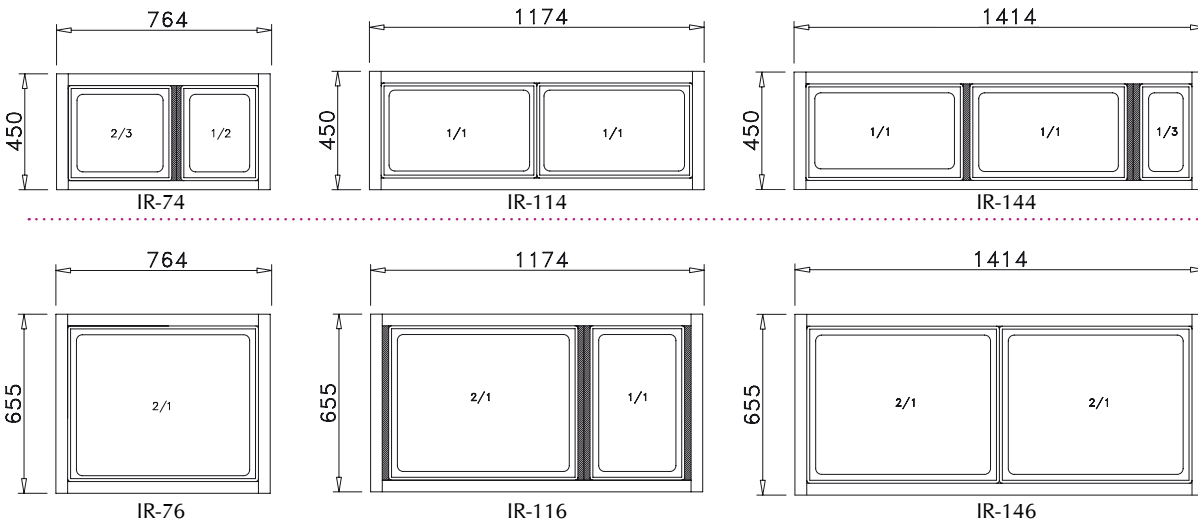

Se instala con facilidad y rapidez. Los estantes se regulan a la altura deseada SIN HERRAMIENTAS, incluso su inclinación.

It can be mounted easily and quickly. Height and lean adjustment according to your needs WITHOUT TOOLS.

Installation facile et rapide. Réglage en hauteur et inclinaison selon vos besoins SANS OUTILS.

Op Opcional / Optional / Optionnel

**Estantes regulables imagine**  
Imagine adjustable wall shelves  
Étagères réglables imagine



Dimensiones  
Dimensions  
Dimensions

L	A	Kg	
764	413	8,2	IR-74
1.174	413	10,4	IR-114
1.414	413	12,4	IR-144
764	614	10,6	IR-76
1.174	614	12,8	IR-116
1.414	614	17,8	IR-146

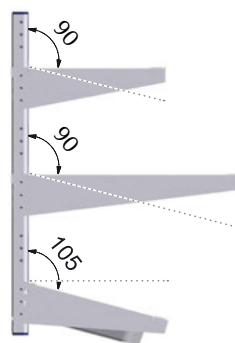

**Montantes**  
Uprights  
Montants



Dimensiones  
Dimensions  
Dimensions

H	Kg	
860	1,5	013606
1.700	3,0	013604

## Cuadro comparativo de estantes murales con cartelas

Comparative view of wall shelves with brackets

Tableau comparatif d'étagères murales avec équerrres

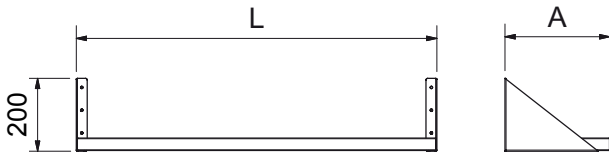
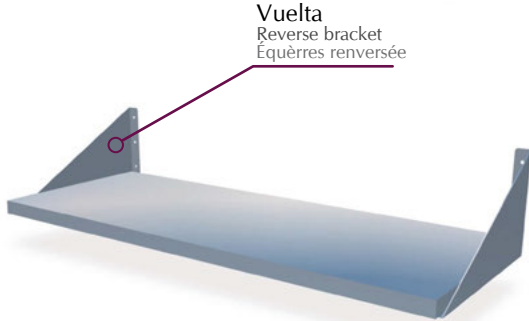

Estos estantes se suelen atornillar a la pared con nuestro tornillo cód. 421034 y con el taco cód. 409824. Ver página 65.

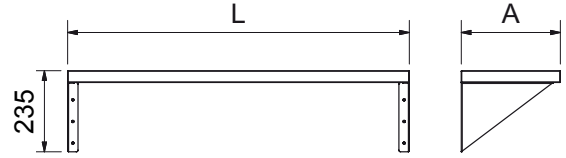

Dimensiones  
Dimensions  
Dimensions

L	A
800	300
1.000	300
1.200	300
1.400	300
800	400
1.000	400
1.200	400
1.400	400
800	500
1.000	500
1.200	500
1.400	500

These shelves generally use our bolt code 421034 and our plug code 409824. See page 65.

Généralement, ces étagères utilisent notre vis code 421034 et notre cheville code 409824. Voir page 65.



**Tornillos y tacos no incluidos en el precio.**  
Bolts and plugs not included in the price.  
Les vises et les chevilles ne sont pas inclus dans le prix.

## Cuadro comparativo de estantes murales con palomillas

Comparative view of wall shelves with supports

Tableau comparatif d'étagères murales avec supports

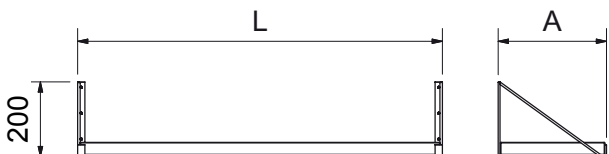
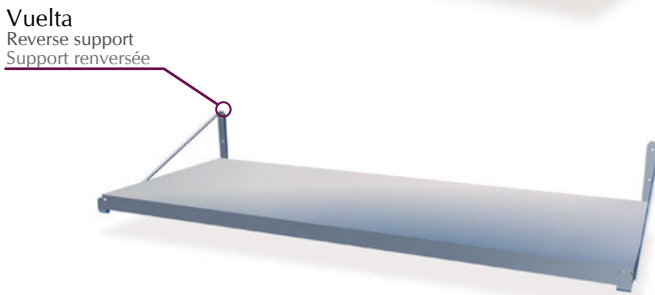

Estos estantes se suelen atornillar a la pared con nuestro tornillo cód. 421034 y con el taco cód. 409824. Ver página 65.

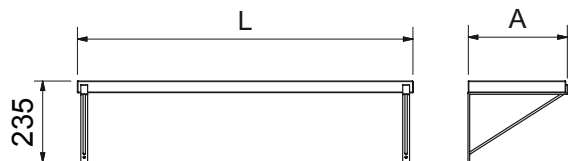

Dimensiones  
Dimensions  
Dimensions

L	A
800	300
1.000	300
1.200	300
1.400	300
800	400
1.000	400
1.200	400
1.400	400
800	500
1.000	500
1.200	500
1.400	500

These shelves generally use our bolt code 421034 and our plug code 409824. See page 65.

Généralement, cet étagères utilisent notre vis code 421034 et notre cheville code 409824. Voir page 65.



**Tornillos y tacos no incluidos en el precio.**  
Bolts and plugs not included in the price.  
Les vises et les chevilles ne sont pas inclus dans le prix.

**Estantes murales**  
Wall shelves  
Étagères murales

Dimensiones  
Dimensions  
Dimensions

L	A	H	Kg	Barcode
800	300	35	2,20	011602
1.000	300	35	2,78	011604
1.200	300	35	3,24	011606
1.400	300	35	3,76	011608
800	400	35	2,76	011610
1.000	400	35	3,40	011612
1.200	400	35	4,04	011614
1.400	400	35	4,76	011616
800	500	35	3,36	011618
1.000	500	35	4,14	011620
1.200	500	35	4,90	011622
1.400	500	35	5,56	011624

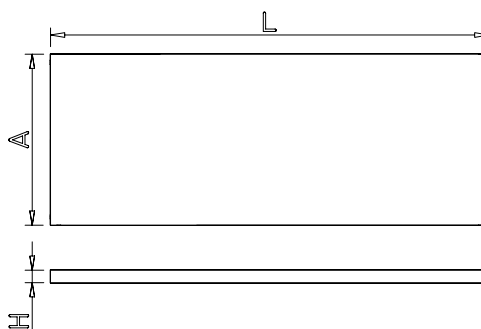

**Cartelas**  
Brackets  
Équerres

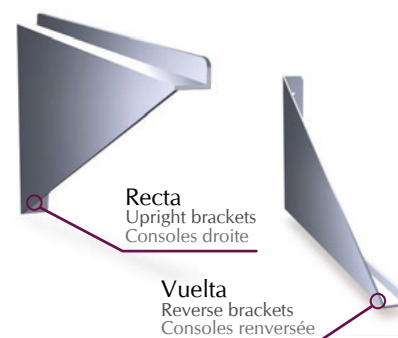
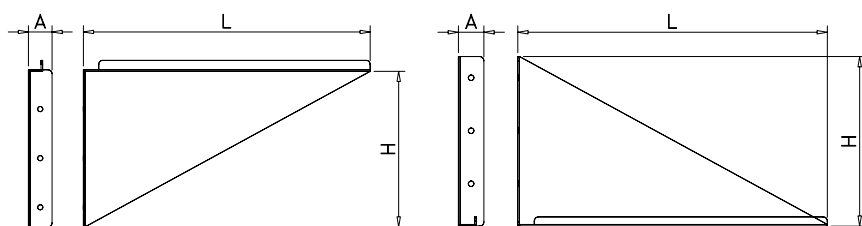

Dimensiones  
Dimensions  
Dimensions

L	A	H	Gr	Barcode 1	Barcode 2	Barcode 3	Barcode 4
265	20	200	500	012402	012403	012602	012603
365	20	200	700	012404	012405	012604	012605
465	20	200	850	012406	012407	012606	012607



Technical drawings of brackets showing dimensions L, A, and H.

**Palomillas**  
Supports  
Supports

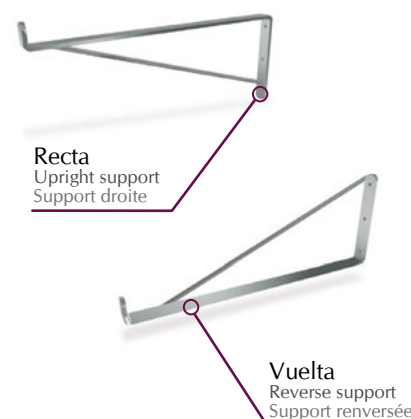
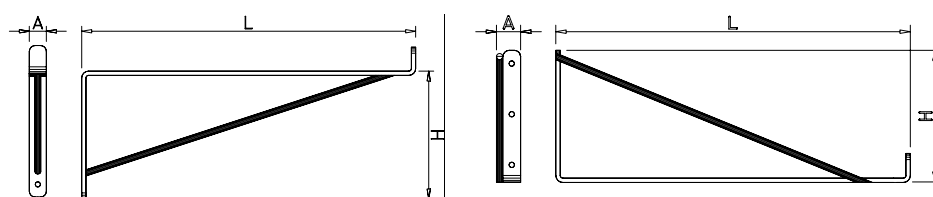

Dimensiones  
Dimensions  
Dimensions

L	A	H	Gr	Barcode 1	Barcode 2	Barcode 3
300	20	200	440	012002	012202	012203
400	20	200	580	012004	012204	012205
500	20	200	700	012006	012206	012207



Technical drawings of supports showing dimensions L, A, and H.



## Estante mural porta-barquetas

Wall shelf for meat plastic trays  
Étagère murale porte-barquettes alimentaires



Estos estantes se suelen atornillar a la pared con nuestro tornillo cód. 421034 y con el taco cód. 409824. Ver página 65.

These shelves generally use our bolt code 421034 and our plug code 409824. See page 65.

Généralement, cet étagères utilisent notre vis code 421034 et notre cheville code 409824. Voir page 65.



**Tornillos y tacos no incluidos en el precio.**  
Bolts and plugs not included in the price.  
Les vises et les chevilles ne sont pas inclus dans le prix.

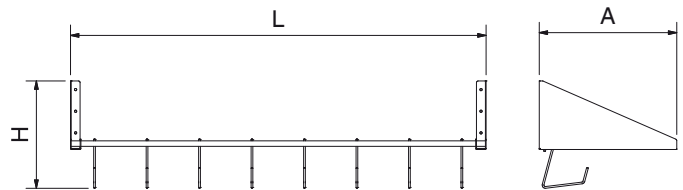
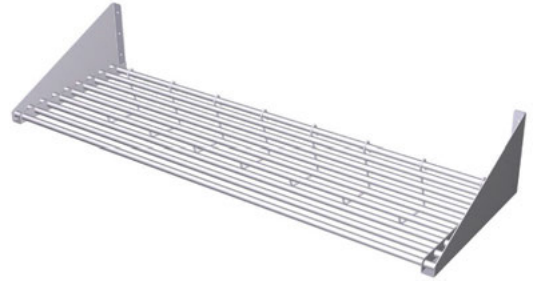

Dimensiones  
Dimensions  
Dimensions

L	A	H	Nº Ganchos Hooks Crochets	Kg	Barcode
1.200	400	310	8	6,80	011920

## Estante mural de fibra abatible

Polyethylene hinged wall shelf  
Console murale battante en polyéthylène



Estos estantes se suelen atornillar a la pared con nuestro tornillo cód. 421034 y con el taco cód. 409824. Ver página 65.



421254 55,00 52

Cartelas abatibles para estantes murales.  
Hinged bracket for wall shelf.  
Équerre battante pour étagère murale.

These shelves generally use our bolt code 421034 and our plug code 409824. See page 65.

Généralement, cet étagères utilisent notre vis code 421034 et notre cheville code 409824. Voir page 65.



**Tornillos y tacos no incluidos en el precio.**  
Bolts and plugs not included in the price.  
Les vises et les chevilles ne sont pas inclus dans le prix.

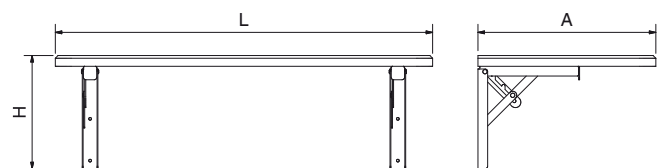

Dimensiones  
Dimensions  
Dimensions

L	A	H	Kg	Barcode
700	330	205	2,00	013206

## Estante mural inclinado para cestas de lavavajillas

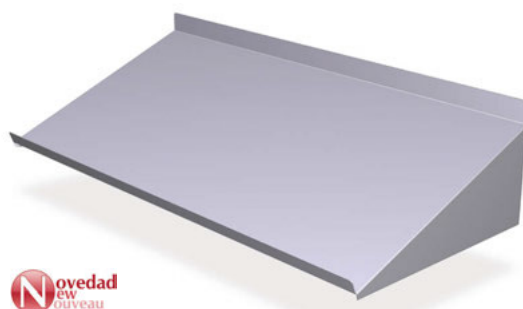

Sloping inclined wall rack shelf  
Étagère murale inclinée pour paniers de lavage

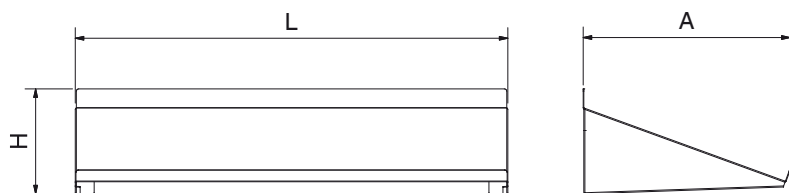

**N**ovedad  
New  
Nouveau



### Dimensiones Dimensions Dimensions

L	A	H			
1.020	488	248	500x500	8,70	011430
1.550	488	248	500x500	12,50	011432

### Características:

Este taburete metálico lleva en su base tres ruedas que permiten su fácil traslado de un sitio a otro con un simple empujón del pie, sin embargo en el momento en que usted sube sobre él queda totalmente fijado al suelo gracias a su burlete circular que se adhiere como una ventosa.

Disponible en otros colores, a partir de 24 unidades.

### Characteristics:

This metallic stool has on its base three castors that allow moving it from one place to another easily, just pushing it with your foot. Furthermore, whenever you are standing on it, it is firmly fixed to the floor, as if it were a suction pad, thanks to its rounded rubber strip.

Available in other colors. From 24 units.



### Caractéristiques:

Ce tabouret métallique a dans sa base trois rouelles qui permettent le déplacer facilement de long en large, avec un seul poussé du pied. En plus, lorsqu'on monte sur lui, il reste totalement fixé au sol, comme une ventouse, grâce à sa bande ronde en caoutchouc.



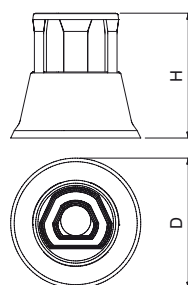

Disponible dans d'autres couleurs. A partir de 24 unités.

## Taburete con ruedas

Rolling step-stool  
Tabouret marche - pied roulant



### Dimensiones Dimensions Dimensions

D	H			
430	430	4,6		482202
430	430	4,6		482204

## Rueda de repuesto para taburetes

Spare wheel for step-stools

Rouelle de rechange pour tabouretes



Repuesto para 482202 y 482204.  
Spare part for 482202 and 482204.  
Rechange pour 482202 et 482204.



482250

## Accesorios para estanterías

Accessories for shelves

Accessoires pour étagères

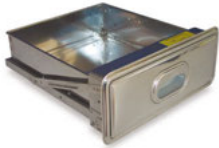

Cajones  
Drawers  
Tiroirs



348



Boxes modulares  
Modular boxes  
Boxes modulaires

226



Ruedas  
Wheels  
Rouelle

353



Taco regulable para soporte de estantería  
Adjustable block for shelving support  
Taquet réglable pour supports de rayonnage

354



Cubetas Gastronorm lisas  
Non-perforated Gastronorm containers  
Bacs Gastronorm lisses

317



# NOVEDADES

ews  
ouveautés

---

<b>Puerta rodante para contenedores</b> Rolling door for waste bin Porte roulante pour conteneur .....	<b>221</b>
<b>Mesas plegables con entrepaño</b> Centre table with shelve Table centrale avec rayon .....	<b>224</b>
<b>Unión en escuadra interior para mostradores de pescadería</b> Fish counter internal-corner link Jonction d'angle interne pour étal à poisson .....	<b>243</b>
<b>Armario para equipos informáticos</b> Wardrobe for computer equipment Cabinet pour matériel informatique .....	<b>254</b>

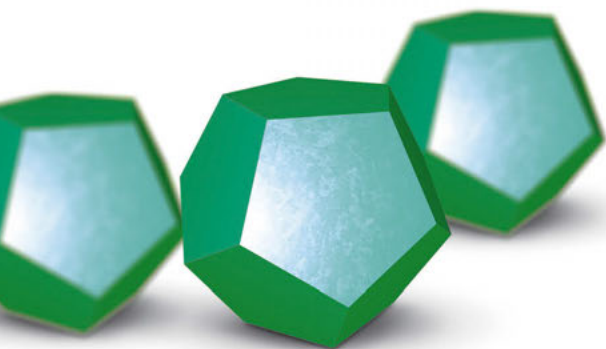

MOBILIARIO  
Neutral furniture  
Meubles neutres





**Detalle de cajón acoplado.**  
Fixed drawer coupled.  
Détail de tiroir couplé.

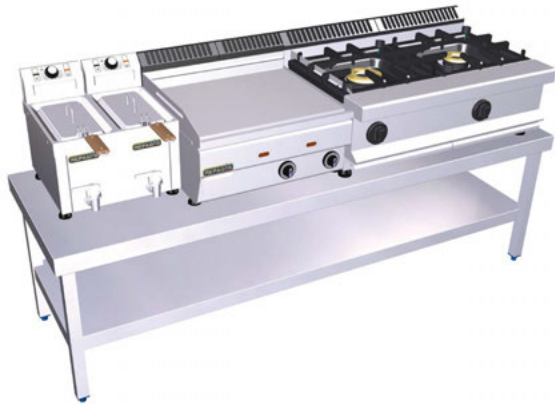

Los modelos con este distintivo pueden fabricarse con altura de 600 mm para cocinas serie snack o modular, sin alterar el precio. Consultar plazo de entrega.

The models with this badge can be manufactured with height 600 mm. for snack or modular stoves without price increasing. Ask delivery time.  
Les modèles avec cet insigne peuvent être fabriqués avec hauteur 600 mm pour snack ou modulaire cuisines sans augmentation de prix. Demandez délai de livraison.

## Manufacturing characteristics:

1.5 mm worktop reinforced and acoustically treated

40x40 mm tubular legs curved to avoid pipes

Adjustable feet to favor stability, since they fit in any floor unevenness.

No wood is used in the manufacture of our tables

Optionally, the following accessories can be installed:



**Detalle de rueda de acero inoxidable con freno acoplada a pata.**  
Detail of wheel in stainless steel with brake fixed to leg.  
Détail de roue en acier inoxydable avec frein installé dans pied.

Drawers	348
Lateral wastepaper bin	287
Knifeholder	130
Wheels	353
Polyethylene fibres	76
Waste receptacle for scraps	282
Fixed sinks	344
Knifeholder disinfectant	248
Containers	272



## Características de fabricación:

Encimera reforzada e insonorizada de 1,5 mm de espesor.

Patas de 40 x 40 mm desplazadas para curva sanitaria, acabado brillante.

Todas las mesas sin entrepaño, a partir de 1.400 mm de longitud, incorporarán crucetas de refuerzo.

En la fabricación de nuestras mesas no empleamos madera.

Se adaptan a cualquier desnivel del suelo ya que disponen de pies regulables.

Opcionalmente se pueden instalar los siguientes accesorios:



Cajones y tolvas de café	348
Papelera lateral	287
Portacuchillos	130
Ruedas	353
Fibras de polietileno	76
Contenedores de desperdicios	282
Tolva de desbarasado	344
Fregaderos soldados	248
Esterilizadores de cuchillos	272

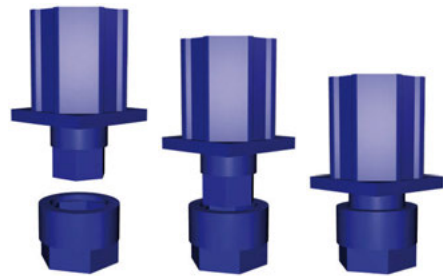

**Detalle de pata con pie regulable con funda antivibratora.**

Detail of adjustable feet with antivibrator cover.  
Détail de pie réglable avec base anti-vibrateur.

## Caractéristiques de fabrication:

Plan renforcé et insonorisé d'1,5 mm d'épaisseur

Empiètements en tube de 40 x 40 décalées pour courbure sanitaire

Empiètements réglables pour favoriser la stabilité, car ils s'adaptent à quelque dénivellement du sol.

Dans la fabrication de nos tables, nous n'employons pas de bois.

Optionnellement on peut installer les suivantes accessoires



Tiroirs et trémie pour marc de café	348
Corbeille à papier lateral	287
Porte couteaux	130
Roues	353
Fibras en polyéthylène	76
Trémie d'évacuation des déchets	282
Eviers soudés	344
Porte-couteaux désinfecteur	248
Conteneurs	272

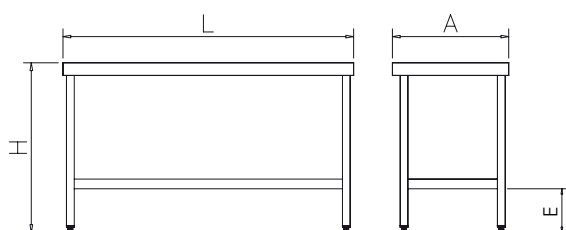
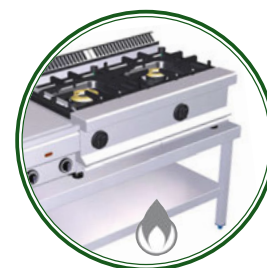

Dimensiones Dimensions Dimensions									
L	A	H	E	Kg		Kg		Kg	
1.000	500	850	200	27,0	070202	23,0	070402	5,0	270202
1.200	500	850	200	32,0	070220	25,0	070420	7,0	270260
1.400	500	850	200	36,0	070222	28,0	070422	8,0	270262
1.500	500	850	200	36,0	070204	29,0	070404	9,0	270204
1.800	500	850	200	45,0	070226	34,0	070426	11,0	270266
2.000	500	850	200	47,0	070206	36,0	070406	13,0	270206
1.000	600	850	200	29,0	070208	25,0	070408	6,0	270208
1.200	600	850	200	35,0	070228	27,0	070428	8,0	270268
1.400	600	850	200	39,0	070230	30,0	070430	9,0	270270
1.500	600	850	200	38,0	070210	32,0	070410	10,0	270210
1.800	600	850	200	48,5	070234	36,0	070434	12,5	270274
2.000	600	850	200	52,0	070212	40,0	070412	15,0	270212
1.000	700	850	200	33,0	070214	29,0	070414	8,0	270214
1.200	700	850	200	39,5	070236	30,0	070436	9,5	270276
1.400	700	850	200	45,0	070238	33,0	070438	12,0	270278
1.500	700	850	200	43,0	070216	34,0	070416	13,0	270216
1.800	700	850	200	56,0	070242	40,0	070442	16,0	270282
2.000	700	850	200	60,0	070218	46,0	070418	19,0	270218



**Mesas murales**  
Wall-side tables  
Tables murales

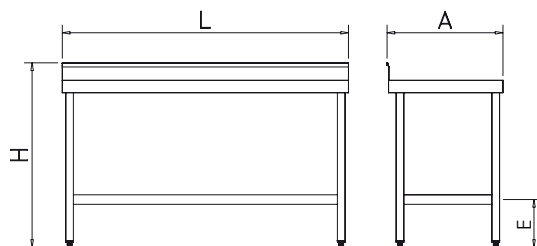

Dimensiones Dimensions Dimensions									
L	A	H	E	Kg		Kg		Kg	
1.000	500	850	200	24,0	070602	21,0	070802	5,0	270202
1.200	500	850	200	30,0	070620	23,0	070820	7,0	270260
1.400	500	850	200	35,0	070622	27,0	070822	8,0	270262
1.500	500	850	200	35,0	070604	29,0	070804	9,0	270204
1.800	500	850	200	44,0	070626	33,0	070826	11,0	270266
2.000	500	850	200	47,0	070606	37,0	070806	13,0	270206
1.000	600	850	200	27,0	070608	23,0	070808	6,0	270208
1.200	600	850	200	34,0	070628	26,0	070828	8,0	270268
1.400	600	850	200	39,0	070630	30,0	070830	9,0	270270
1.500	600	850	200	38,0	070610	32,0	070810	10,0	270210
1.800	600	850	200	48,5	070634	36,0	070834	12,5	270274
2.000	600	850	200	52,0	070612	40,0	070812	15,0	270212
1.000	700	850	200	31,0	070614	26,0	070814	8,0	270214
1.200	700	850	200	38,5	070636	29,0	070836	9,5	270276
1.400	700	850	200	47,0	070638	35,0	070838	12,0	270278
1.500	700	850	200	45,0	070616	37,0	070816	13,0	270216
1.800	700	850	200	57,0	070642	41,0	070842	16,0	270282
2.000	700	850	200	61,0	070618	46,0	070818	19,0	270218

## Mesas murales con puertas

Wall-side tables with doors  
Tables murales avec portes



### Características:

Laterales y trasera forrados en acero inoxidable. Entrepaño inferior a 200 mm del suelo y el otro centrado.

La principal ventaja de nuestras mesas de puertas correderas consiste en que las puertas van colgadas, lo que evita depósitos de suciedad en carriles y entrepaños. Tiradores integrados en la puerta.

### Characteristics:

Sides and back covered with stainless steel panels. Centered shelf.

The main advantage of our sliding doors tables consists on their hanging doors. They avoid dirtiness deposits in rails and shelves. Furthermore the handles are integrated in the door.

### Caractéristiques:

Latérales et fond recouvertes en acier inoxydable. Tablette-rayon centré.

La principale avantage de nos tables à portes coulissantes c'est que ses portes sont suspendues pour éviter des dépôts de saleté dans les rails et dans les tablettes-rayons. En plus les poignées sont intégrées dans la porte.

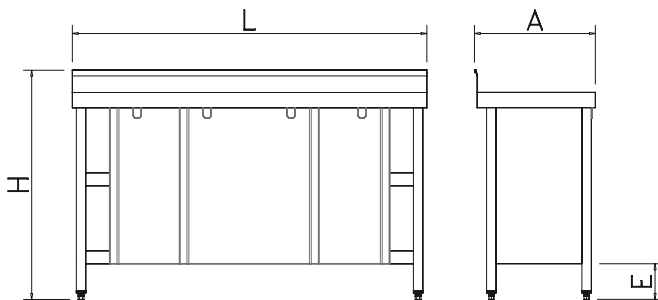

Dimensiones Dimensions Dimensions				Correderas Sliding doors Coulissantes			Abatibles Hinged doors Deux battants			
L	A	H	E	Kg	Barcode	Quantity	Kg	Barcode	Quantity	
1.000	500	850	200	40,0	073802	2	42	074002	2	
1.200	500	850	200	48,0	073820	2				
1.400	500	850	200	52,0	073822	3				
1.500	500	850	200	56,0	073804	3	59	074004	3	
1.800	500	850	200	62,5	073826	4				
2.000	500	850	200	67,0	073806	4	71	074006	4	
1.000	600	850	200	43,0	073808	2	45	074008	2	
1.200	600	850	200	50,5	073828	2				
1.400	600	850	200	55,0	073830	3				
1.500	600	850	200	58,0	073810	3	61	074010	3	
1.800	600	850	200	62,5	073834	4				
2.000	600	850	200	77,0	073812	4	81	074012	4	
1.000	700	850	200	48,0	073814	2	50	074014	2	
1.200	700	850	200	56,0	073836	2				
1.400	700	850	200	61,0	073838	3				
1.500	700	850	200	64,0	073816	3	67	074016	3	
1.800	700	850	200	74,0	073842	4				
2.000	700	850	200	84,0	073818	4	88	074018	4	

## Armarios de puertas correderas

Cupboards with sliding doors  
Armoires à portes coulissantes



### Características:

Laterales y trasera forrados de acero inoxidable.  
Entrepañó intermedio.  
Tiradores integrados en la puerta.  
Puertas colgadas, con lo que se evitan depósitos de suciedad en carriles y entrepaños.

### Characteristics:

Back and sides covered with stainless steel panels. Centered shelf.  
The main advantage of our sliding doors tables consists on their hanging doors. They avoid dirtiness deposits in rails and shelves. Furthermore the handles are integrated in the sheet.

### Caractéristiques:

Latérales et retour recouvertes en acier inoxydable. Tablette-rayon centré.  
La principale avantage de nos tables à portes coulissantes c'est que ses portes sont suspendues pour éviter des dépôts de saleté dans les rails et dans les tablettes-rayons. En plus les poignées sont intégrées dans la plaque.



Vista de mesa y armario.  
Table and wardrobe view.  
Vue de table et armoire.

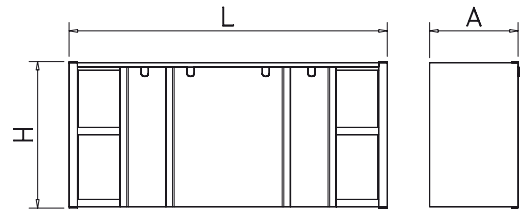

Dimensiones Dimensions Dimensions					
L	A	H		Kg	Barcode
1.000	300	610	2	28	080806
1.400	300	610	3	38	080808
1.000	400	610	2	30	080802
1.400	400	610	3	40	080804

## Mesas murales a pared

Wall-fitted tables  
Tables à fixer au mur

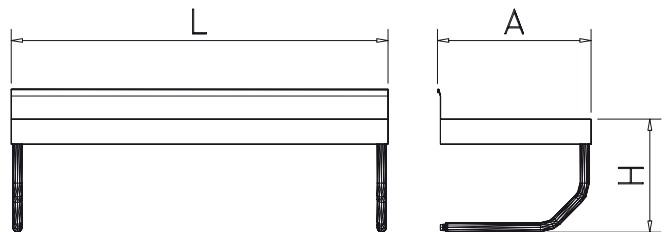

Dimensiones Dimensions Dimensions					
L	A	H		Kg	Barcode
1.000	500	450	17	071002	
1.500	500	450	22	071004	
1.000	600	450	23	071006	
1.500	600	450	28	071008	
1.000	700	450	26	071010	
1.500	700	450	34	071012	

**Mesas murales de esquina**  
 Corner wall-side tables  
 Tables murales d'angle

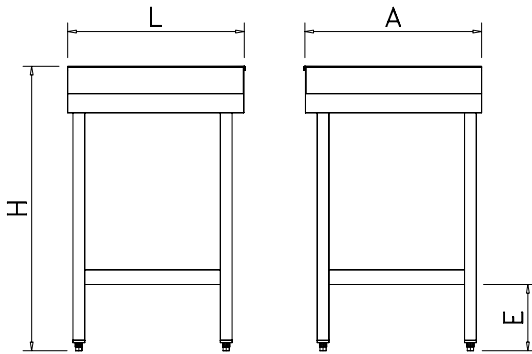

Dimensiones Dimensions Dimensions				Con entrepaño With shelf Avec tablette-rayon		Sin entrepaño Without shelf Sans tablette-rayon	
L	A	H	E	Kg	Barcode	Kg	Barcode
500	500	850	200	20	074602	19	074802
600	600	850	200	23	074604	22	074804
700	700	850	200	26	074606	25	074806

**Mesas murales de Chef**  
 Chef wall-side table  
 Table murale de chef

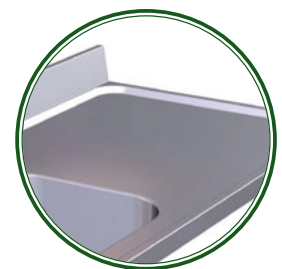
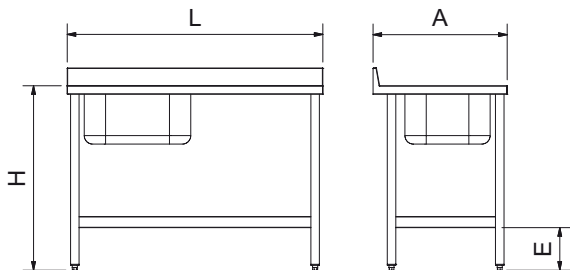
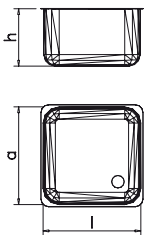

	Dimensiones Dimensions Dimensions							Con entrepaño With shelf Avec tablette-rayon		Sin entrepaño Without shelf Sans tablette-rayon	
	L	A	H	E	l	a	h	Kg	Barcode	Kg	Barcode
	1.200	600	850	200	500	400	250	27	075202	24	075402
	1.200	700	850	200	500	500	300	29	075206	26	075406
	1.200	600	850	200	500	400	250	27	075204	24	075404
	1.200	700	850	200	500	500	300	29	075208	26	075408

## Mesa mural desbarasado con fregadero

Wall-side table for waste chutes with sink  
Table murale vide déchets avec bac

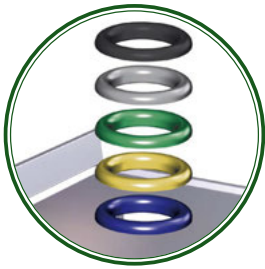
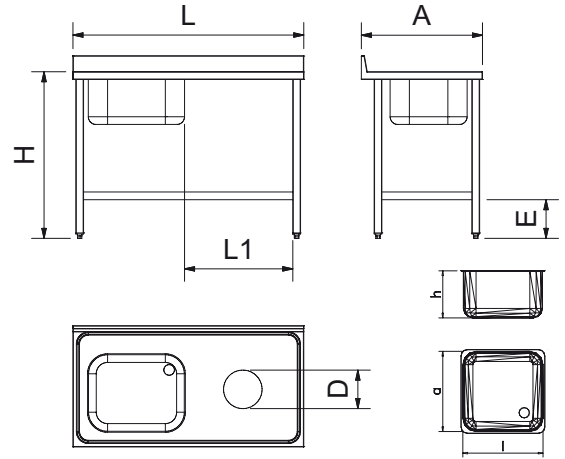

Dimensiones Dimensions Dimensions											
	L	A	H	E	I	a	h	L1	D	Kg	Barcode
	1.200	600	850	200	500	400	250	570	200	24,5	MD-60-I
	1.200	700	850	200	500	500	300	570	200	26,5	MD-70-I
	1.200	600	850	200	500	400	250	570	200	24,5	MD-60-D
	1.200	700	850	200	500	500	300	570	200	26,5	MD-70-D

## Mesa mural desbarasado con puerta

Waste chutes wall-side table  
Table murale pour trémie à déchets

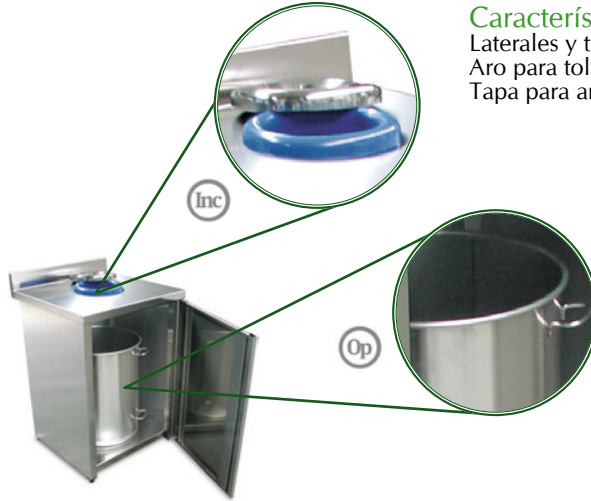

### Características:

Laterales y trasera forrados en acero inoxidable.  
Aro para tolva de desbarasado color azul.  
Tapa para aro.

### Characteristics:

Sides and back covered with stainless steel panels.  
Blue ring for waste chutes.  
Ring lid.

### Caractéristiques:

Latérales et fond recouvertes en acier inoxydable.  
Cercle bleu pour trémies à déchets.  
Couvercle.

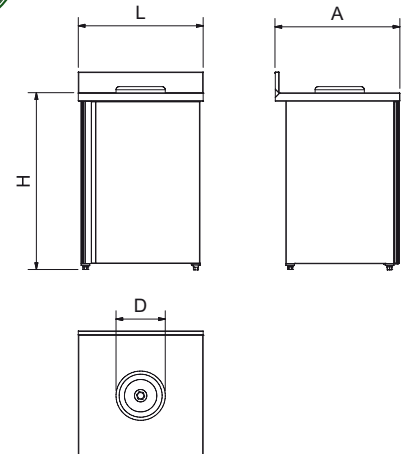

Incluido / Included / Inclus  
 Opcional / Optional / Optionnel



Ejemplo de zona de lavado. Posibilidad de diferentes combinaciones al poder colocar la mesa a uno u otro lado.

Example of rinse zone. Possibility of different combinations with the table on one side or the other.

Exemple de zone de lavage. Possibilité de diverses combinaisons avec la table d'un côté ou de l'autre.

### Dimensiones Dimensions Dimensions

L	A	H	D	Kg	Barcode
600	600	850	235	23	074438
600	700	850	235	28	074437

**Puerta rodante para contenedores**  
 Rolling door for waste bin  
 Porte roulante pour conteneur



**N**ovedad  
 ew  
 iveau

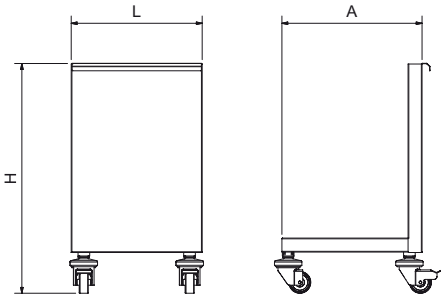

Dimensiones  
 Dimensions  
 Dimensions

L	A	H	Kg	Barcode
460	500	780	11	074472

**Mesa de preparación de verduras**  
 Vegetable preparation table  
 Table de préparation de légumes

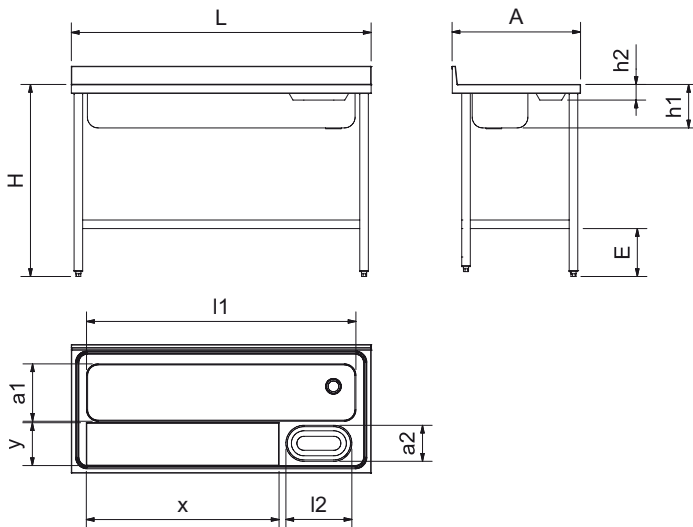

Dimensiones  
 Dimensions  
 Dimensions

L	A	H	E	l1	a1	h1	l2	a2	h2	X	Y	Kg	Barcode
1.400	600	850	200	1.250	260	180	300	160	50	925	215	28,0	075602



## Mesas de preparación y lavado

Preparation and cleansing tables

Tables de préparation et de lavage



### Dotación y características de fabricación:

Totalmente construida con acero inoxidable.  
Fibra de polietileno calidad P-500.  
Fregadero soldado con válvula, tapón y rebosadero.  
Tolva de evacuación de desperdicios.

### Features and manufacturing characteristics:

Made totally from stainless steel.  
P-500 quality polyethylene fibre.  
Welded bowl with valve, plug and overflow.  
Hole for waste-chutes

### Dotation et caractéristiques de fabrication:

Entièrement fabriquées en acier inoxydable.  
Fibre de polyéthylène qualité P-500.  
Bac soudée avec valve, déversoir.  
Trou pour tremie à déchets.



#### Posibilidad de fregadero a la derecha.

Possibility to place the sink on the right.  
Possibilité de placer le réservoir sur la droite.



#### Repuestos de fibras.

Spare fibres.  
Fibres de rechange.



78

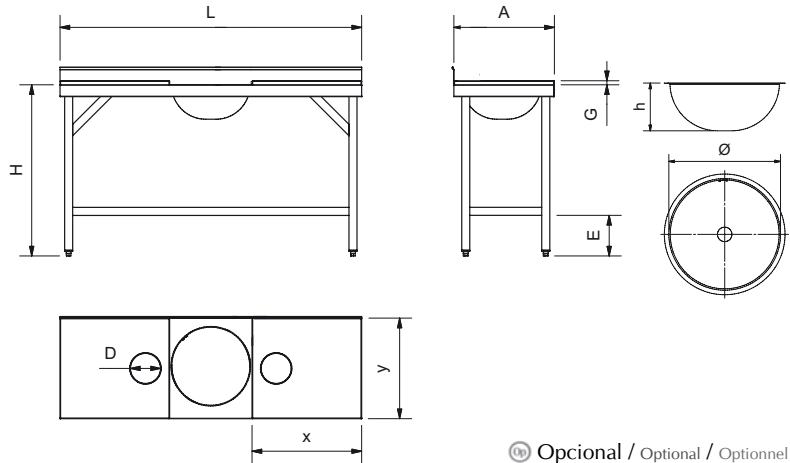

Ⓜ Opcional / Optional / Optionnel

### Dimensiones Dimensions Dimensions

	L	A	H	E	Ø	h	X	y	G	D	Kg	Barcode
	1.000	500	850	200	390	170	545	500	20	150	28	072802 072880 072852
	1.500	500	850	200	390	170	760	500	20	235	43	072812 072884 072862
	1.500	500	850	200	390	170	545	500	20	150	50	072822 072888 072872

**Mesa mural de prelavado**  
Pre-rinse wall-side table  
Table mural de pré lavage



**Dotación y características de fabricación:**  
Totalmente construida en acero inoxidable, provista de reborde perimetral salva-aguas. Esta mesa está diseñada para albergar un lavavajillas y un contenedor de residuos bajo ella. Además hay espacio útil para depositar las cestas en la encimera antes del desbarasado. Dotada de fregadero soldado con válvula, tapón, rebosadero y tolva de evacuación de desperdicios.

**Equipment and manufacturing characteristics:**  
Worktop made in stainless steel. Manufactured with perimeter raised edge to avoid water pouring. This table has been designed to lodge a dishwasher and a waste bin below. In addition there is spare room enough to deposit basket in the worktop before the waste of scraps. Provided with welded sink with valve, plug and overflow and ring for waste chutes.

**Équipement et caractéristiques de fabrication:**  
Dessus construit en acier inoxydable. Fabriquée avec rebord dans le périmètre pour éviter des reversement d'eau. Cette table a été dessinée pour allouer un lave-vaisselles et un conteneur de déchets dessous. En plus, il y a espace libre pour déposer des paniers dans le dessus avant l'évacuation des déchets. Pourvu avec plonge soudé avec valve, bouchon et déversoir et trémie d'évacuation de déchets.

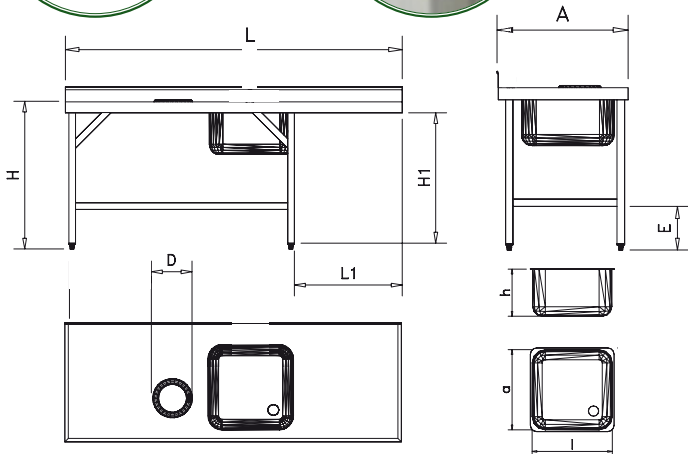

Dimensiones Dimensions Dimensions												
	L	A	H	I	a	h	L1	H1	D	E	Kg	Barcode
■	2.000	700	850	500	500	300	610	890	235	200	40	074435
■	2.000	700	850	500	500	300	610	890	235	200	40	074436

**Características:**  
Provistas de cajones con rodamientos totalmente contruidos en acero inoxidable. Faldón y laterales forrados en zona de cajones.

**Characteristics:**  
Supplied with drawers, with all bearings made from stainless steel. Skirt, and the sides lined in the drawers zone.

**Caractéristiques:**  
Munies de tiroirs avec roulements entièrement fabriqués en acier inoxydable. Habillage et côtés recouverts au niveau des tiroirs.

**Mesas murales de cajones**  
Wall-side tables with drawers  
Tables murales à tiroirs

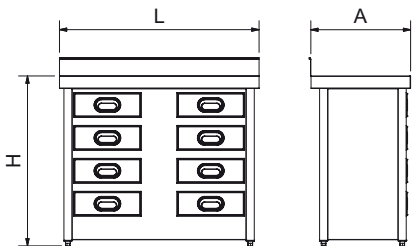

Dimensiones Dimensions Dimensions		4 Cajones 4 Drawers 4 Tiroirs				8 Cajones 8 Drawers 8 Tiroirs			
L	A	H	E	Kg	Barcode	Kg	Barcode	Kg	Barcode
1.000	500	850	200	44	074202	57	074252		
1.000	600	850	200	48	074204	60	074254		
1.000	700	850	200	54	074206	65	074256		

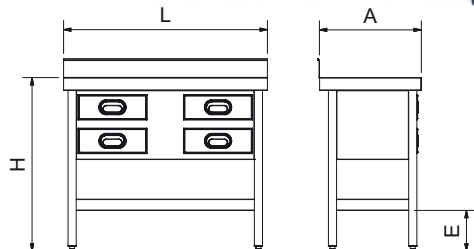

## Mesas plegables con entrepaño

Centre table with shelve  
Table centrale avec rayon



### Características:

Fácil transporte.  
Fácil almacenaje.  
Patas escamoteables hasta alcanzar 1.200x600x63 mm.  
Totalmente en acero inoxidable.

### Characteristics:

Easy to move.  
Easy to store.  
Retractable legs to 1200x600x63 mm.  
Wholly made of stainless steel.

### Caractéristiques:

Facile à déplacer.  
Facile à ranger.  
Pieds rétractables à 1200x600x63 mm.  
Entièrement réalisé en acier inoxydable.

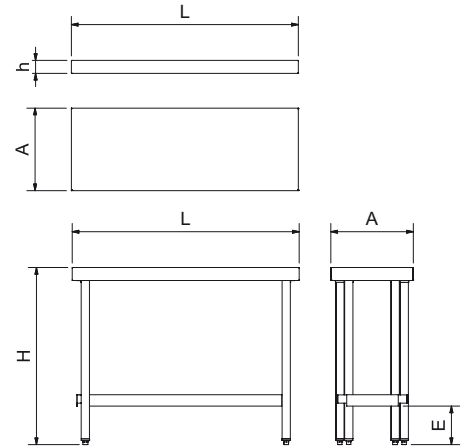
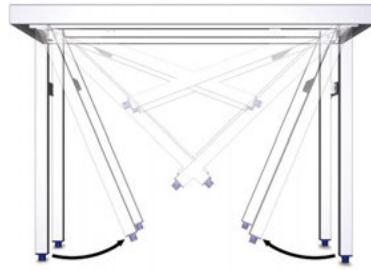

### Dimensiones Dimensions Dimensions

L	A	H	E	h	Kg	Barcode
1.100	400	860	187	63	16,0	075804
1.300	400	860	187	63	18,0	075806
1.100	500	860	187	63	17,0	075808
1.300	500	860	187	63	19,0	075810

## Mesa mural satabanco con dos entrepaños

Console table with two shelves  
Table console avec deux tablettes-rayons

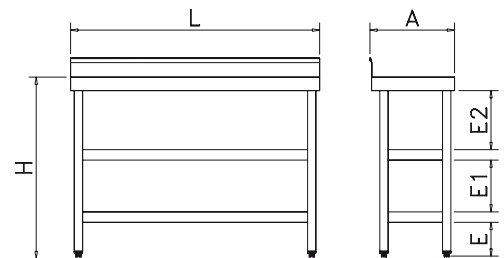

### Dimensiones Dimensions Dimensions

L	A	H	E	E1	E2	Kg	Barcode
1.000	400	850	200	243	243	15,95	074408
1.200	400	850	200	243	243	19,95	074410

## Mesa central con dos entrepaños. Especial cortadoras de fiambre

Centre table with two shelves. Specially for cutting machines  
Table centrale avec deux rayons. Special pour machines à couper

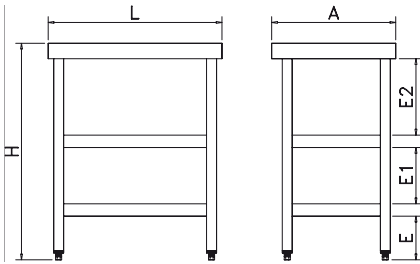

### Dimensiones Dimensions Dimensions

L	A	H	E	E1	E2	Kg	Barcode
705	505	855	150	270	270	18	074402

## Soporte sobre-mostrador para cortadoras de fiambre

Stand support for cold meat cutting  
Support sur comptoir pour coupe-charcuterie

### Características:

Altura regulable.

Las guías inferiores son regulables para la adaptación al ancho de la tapa del evaporador de cualquier vitrina.

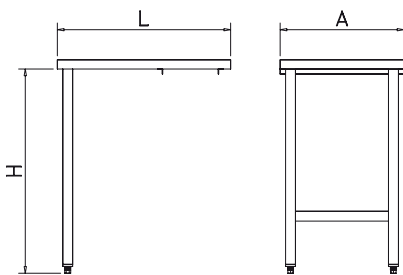

### Characteristics:

Adjustable height.  
The lower rails are adjustable to adapt the width of the evaporator cover to any display.

### Caractéristiques:

Hauteur réglable.  
Les rails inférieurs sont réglables pour l'adaptation du largeur du couvercle de l'évaporateur à quel-que comptoir.

### Dimensiones Dimensions Dimensions

L	A	H	Kg	Barcode
690	490	802-882	8,15	082204

## Mesa central con entrepaño. Especial maquinaria

Centre table with shelf. Specially for machines  
Table centrale avec rayon. Special pour machinerie

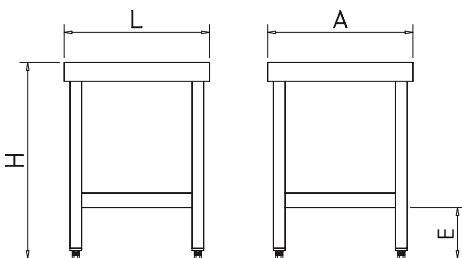

### Dimensiones Dimensions Dimensions

L	A	H	E	Kg	Barcode
505	505	655	150	15	074422

## Boxes modulares

Modular boxes

Boxes modulaires



With this system of modular boxes now you can adapt to your needs tables, sink units, shelving units, etc.

Based in the international dimensions Gastronorm, it is made totally from stainless steel. Its innovative and functional design allows the fitting of elements such as guides, drawers, pans, doors, etc.

Avec le système de boxes modulaires maintenant vous pouvez adapter à vos besoins tables, éviers, étagères, etc.

Ce système, basé dans les mesures internationales Gastronorm, est fabriqué totalement en acier inoxydable. Sa conception moderne et fonctionnelle permet d'adapter guides, tiroirs, bacs, portes, etc.

Con este sistema de boxes modulares ya puede configurar a su medida las mesas, fregaderos, estanterías, etc.

Basados en las dimensiones internacionales GASTRONORM están fabricados totalmente en acero inoxidable. Su diseño moderno y funcional permite adaptar guías, cajones, cubetas, puertas etc.



Dimensiones Dimensions Dimensions							
	L	A	H <sub>int</sub>	H <sub>ext</sub>	Kg	Barcode	
<b>Box modular 4 cajones</b> Box 4 drawers unit Box modulaire 4 tiroirs	439	423	530	600	19,00	075002	
<b>Box modular 1 cajón y puerta</b> Box 1 drawer and door unit Box modulaire 1 tiroir et porte	439	423	530	600	16,00	075004	
<b>Box modular guías GN</b> Box GN guides unit Box modulaire GN guides	439	423	530	600	10,00	075006	
<b>Box modular 1 puerta</b> Box 1 door unit Box modulaire 1 porte	439	423	530	600	13,00	075008	

## Kit golpeador para cajón modular

Coffee grounds striker kit for modular drawer

Kit de barre pour vider le marc de café pour tiroir modulaire

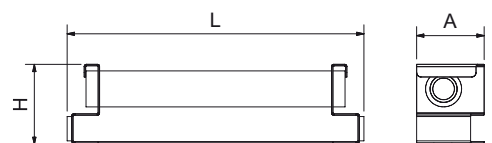
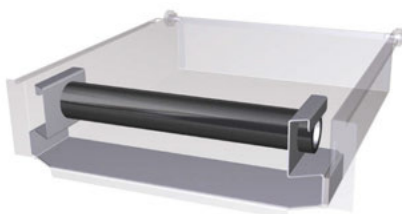

Concepto Concept Concept		Dimensiones Dimensions Dimensions					
	Barcode	L	A	H	Kg	Barcode	
Precio para montaje en fábrica Assembly price Prix pour accoupler	075020	330	75,5	89	2,1	275128	

## Estanterías de sobremesa

Desktop shelves  
Etagères à poser sur table

081802 € 30 332 Op

Porta-notas mural  
Wall mounted note-holder  
Porte-notes mural

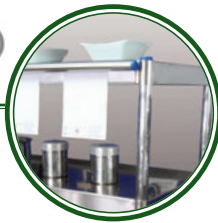

085014 € 8 Op

Kit de fijación  
Fixing kit  
Kit de fixation



Estantes regulables en altura  
Adjustable shelves  
Etagères réglables en hauteur

Entrepaño opcional  
Optional shelf  
Tablette en option

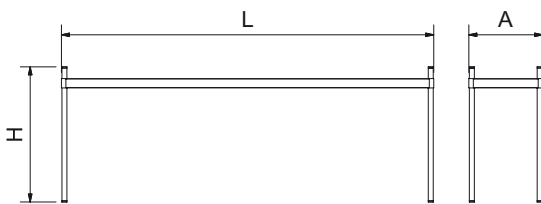

Dimensiones Dimensions Dimensions						
L	A	H	Kg	Barcode	Kg	Barcode
991	391	677	3,8	076060	3,6	276060
1.391	391	677	5,1	076062	4,9	276062
1.891	391	677	6,7	076064	6,5	276064



Instalación de sobremesa con o sin fijación.  
Installation on worktop with or without attachment.  
Installation sur dessus avec ou sans fixation.

Incluido / Included / Inclus

Opcional / Optional / Optionnel

## Calentador de platos para estante de sobremesa

Dish heater for desktop shelves  
Bande chauffante pour étagères à poser sur table

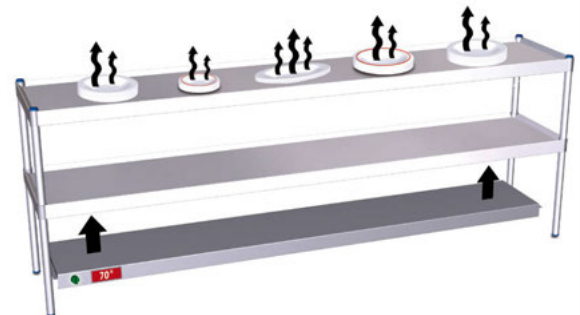

### Características:

Instalación sin herramientas bajo estante de sobremesa.

### Characteristics:

Tool-free installation under table shelf.

### Caractéristiques:

Installation sans outil sous l'étagère de la table.

Dimensiones Dimensions Dimensions	Tensión Voltage Tension	Frecuencia Frequency Frequence	Potencia Power Puissance		
L				Kg	Barcode
955	220 V	50 Hz	1.000 W	4,8	076070
1.355	220 V	50 Hz	1.500 W	6,0	076072
1.855	220 V	50 Hz	1.500 W	7,0	076074





## Contenedor inox para vaciado de bandejas de comida rápida

Stainless steel waste bin for fast-food tray's emptying

Poubelle en acier inoxydable spéciale snack restauration rapide



Apertura a pedal  
Foot pedal opening  
Ouverture à pédale



### Características de fabricación:

Fabricado totalmente con acero inoxidable.  
Sistema patentado de pedal. Permitirá al usuario abrir la trampilla sin necesidad de usar las manos. La trampilla también se puede abrir con la mano en caso de requerirlo.  
Las varillas de la parte superior del mueble facilitan la colocación de las bandejas.  
La tolva de caída de los desperdicios es de una sola pieza y no posee juntas ni huecos, lo que facilita la limpieza.  
Asa de la puerta ergonómica.  
El contenedor posee dos ruedas, lo que permite desplazarlo con poco esfuerzo.  
Provisto de dos tacos regulables en altura para adaptarse a cualquier clase de suelo, evitando desplazamientos accidentales o no deseados.  
Insonorizado en todas sus piezas.  
Gran capacidad. Puede albergar un cubo de hasta 500 x 510 mm y 740 mm de altura.

### Manufacturing characteristics:

Wholly made of stainless steel.  
Pedal operated patented system. It will allow the user to open the lid avoiding the use of his hands. The lid can also be opened with the hand if necessary.  
Rods on the top that make easier the placing of the empty trays.  
Receptacle for scraps made in one only piece, without joints or hollows.  
Ergonomic handle.  
It can be moved effortlessly by means of two wheels.  
It can be adapted to any floor unevenness thanks to two adjustable blocks.  
All its components are soundproofed.  
High capacity. It can lodge a container up to width 500 x 510 mm. x 740 mm.



480666 € Op  
57,00

Adhesivo "Camaleón"  
Sticker "Chameleon"  
Autocollant "Caméléon"



480662 € Inc  
21,00

Adhesivo trampilla  
Sticker for lid  
Autocollant pour trappe



480664 € Inc  
21,00

Adhesivo para pedal  
Sticker for pedal  
Autocollant pour pédale



486022 € Inc  
27,00 282

Contenedor de desperdicios  
Waste bin  
Conteneur à ordures



485024 € Inc  
31,00

Ruedas  
Wheels  
Rouelles



### Caractéristiques de fabrication:

Fabricado totalmente en acero inoxidable.  
Système patenté de pédale. Permettra à l'utilisateur ouvrir la trappe sans avoir besoin d'utiliser les mains. La trappe peut aussi être ouverte avec les mains.  
Les tiges de la partie supérieure du meuble facilitent le rangement des plateaux.  
La trémie de déchets est construite dans une seule pièce et elle ne possède pas de joints, ce qui facilite le nettoyage.  
Tireur ergonomique.  
La poubelle a deux rouelles, ce qui permet de le déplacer sans effort.  
Elle est pourvue de deux vérins réglables en hauteur pour s'adapter au plancher.  
Toute la poubelle est insonorisée.  
Grande capacité. Peut contenir une poubelle de dimensions jusqu'à 500 mm x 510 mm et 740 mm d'hauteur.

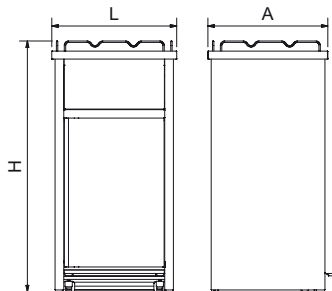

Inc Incluido / Included / Inclus  
Op Opcional / Optional / Optionnel

Dimensiones  
Dimensions  
Dimensions

L	A	H	Kg	080660
625	600	1.255	46,0	080660

Dotación de serie:

- 4 Cubetas GN 1/9 de 100 mm
- 3 Cubetas GN 1/2 de 200 mm
- 1 Fibra negra de 200x250x15 mm
- 1 Agujero evacuación de desperdicios.
- 1 Grifo monomando extensible cod. 463206
- 1 Cubeta fregadero Ø260x115 mm
- 1 Entrepañó.
- 4 Tacos regulables rosca sanitaria.

Equipment included:

- 4 Containers GN 1/9 100 mm
- 3 Containers GN 1/2 200 mm
- 1 Black cutting board 200x250x15 mm
- 1 Waste chutes hole.
- 1 One handle elbow functioning tap, extending shower. Code 463206
- 1 Sink Ø 260x115 mm
- 1 Shelf
- 4 Plastic adjustable feet with thread inside.



Équipement inclus:

- 4 Bacs GN 1/9 100 mm
- 3 Bacs GN 1/2 200 mm
- 1 Plaque de découpe noire 200x250x15 mm
- 1 Trou à déchets.
- 1 Robinet monocommande à coude, douche extensible. Cod 463206
- 1 Évier Ø 260x115 mm
- 1 Tablette-rayon.
- 4 Taquets réglables avec filet intérieur.



083060 76,00 331

Botellero  
Wine rack  
Porte-bouteilles

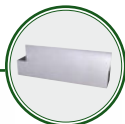

461430 15 151

Bidón de 11 lts  
11 litres water drum  
Bidon d'eau de 11 litres



486024 20 284

Contenedor de desperdicios  
y reciclaje  
Waste and recycling container  
Conteneur à ordures et recyclage



352

Ruedas  
Wheels  
Rouelles

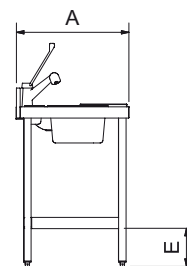
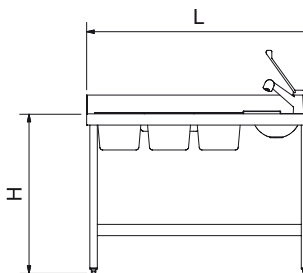
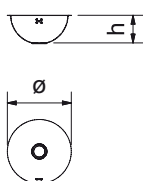
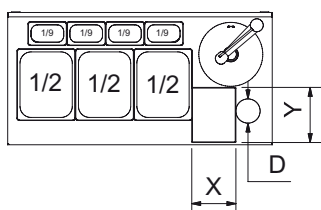

Dimensiones  
Dimensions  
Dimensions

L	A	H	E	D	X	Y	h	Ø	Kg	
1.200	600	850	200	110	200	250	115	260	42,0	075250

☑ Includo / Included / Inclus  
☐ Opcional / Optional / Optionnel

## Carros de servicio

Service trolley

Chariot de service



**\*HASTA 140 Kg**  
de carga por estante

Up to 140 kgs of load strength per shelf  
Jusqu'à 140 kgs de résistance par étage

### Características:

Concebido para un uso intensivo profesional.

Estantes regulables en altura. Pliegues reforzados con pestaña aplastada, lo que evita accidentes durante su uso y limpieza y aumenta la capacidad de carga hasta 140 kg por nivel. Posibilidad de añadir más estantes. Máxima carga admisible 280 kg.

Se suministra con 4 ruedas giratorias, dos de ellas con freno, diámetro 125 mm, provistas de superficie de rodadura de baja sonoridad.

Parachoques circulares de 95 mm de diámetro.

Amplia gama de accesorios opcionales.



454860 3,00 330



Cestillo para cubiertos  
Cutlery basket  
Couverts panier

### Characteristics:

Designed for intensive and professional work.

Adjustable shelves, reinforced by special fold with crushed fringe. This system avoids any bad cut when handling and cleaning it and increases its load strength. Every shelf can support up to 140 kgs evenly distributed. Possibility of increasing its number of shelves. Maximum load strength 280 kgs.

Provided with 4 castors of diameter 125 mm., 2 of them with brake, with tread band of low noise level.

Rounded bumpers of 95 mm. of diameter.

Wide range of optional accessories.



486024 20 284



Contenedor de desperdicios y reciclaje azul  
Coupled wheels  
Rouelles accouplées



317

Cubetas Gastronorm  
Gastronorm containers  
Cuveau Gastronorm



276040 26 231

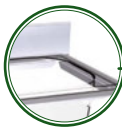

Adaptador de cubeta GN 1/3 y 1/6  
Gastronorm trays adaptor GN/1/3 and 1/6 for service trolleys  
Adaptateur de bacs Gastronorm 1/3 et 1/6 pour chariots de service

### Caractéristiques:

Conçu pour une utilisation intensive professionnelle.

Étagères réglables en hauteur. Plis renforcés avec bord aplati ce qui évite des accidents lors de son utilisation et nettoyage en plus d'augmenter sa capacité de charge jusqu'à 140 kg par niveau. Charge maximale : 280 kg. Il existe la possibilité d'ajouter des étagères.

Muni de 4 roulettes pivotantes, dont 2 avec frein, diamètre 125 mm et bande de roulage à bas niveau de bruit.

Pare-chocs ronds de 95 mm diamètre

Ample gamme de accessoires optionneaux.



276044 32 231

Adaptador contenedor desperdicios  
Cutlery basket adaptor for service trolleys  
Adaptateur de conteneurs pour chariots de service

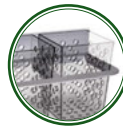

276042 26 231

Adaptador de cestillos cuberteros  
Container adaptor for service trolleys  
Adaptateur de panier à utensiles de cuisine pour chariots de service

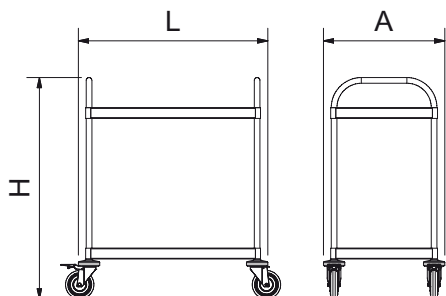

Dimensiones Dimensions Dimensions						Entrepaino opcional Optional shelf Tablette en option	
L	A	H	Kg	Kg	Barcode	Kg	Barcode
835	535	975	140	15	076002	3,5	276050
1.035	535	975	120	16	076004	4,3	276052
1.235	535	975	120	18	076006	5,0	276054

\*El peso máximo soportado está calculado para una carga repartida uniformemente sobre toda la superficie del estante.  
The weight capacity is calculated for a uniformly distributed load over the entire surface of the shelf  
La capacité de charge est calculée pour une charge uniformément répartie sur toute la surface du plateau

## Adaptador de cubetas GN 1/3 y 1/6 para carros de servicio

Gastronorm trays adaptor GN 1/3 and 1/6 for service trolleys  
Adaptateur de bacs Gastronorm 1/3 et 1/6 pour chariots de service

Dimensiones Dimensions Dimensions			
L	A	Gr	Barcode
355	216	780	276040

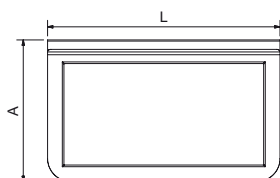

## Adaptador de cestillos cuberteros para carros de servicio

Cutlery basket adaptor for service trolleys  
Adaptateur de panier à utensiles de cuisine pour chariots de service

Dimensiones Dimensions Dimensions			
L	A	Gr	Barcode
360	159	792	276042

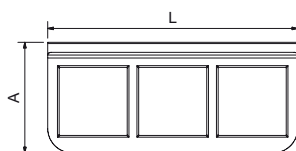

## Adaptador de contenedores para carros de servicio

Container adaptor for service trolleys  
Adaptateur de conteneurs pour chariots de service

Dimensiones Dimensions Dimensions			
L	A	Gr	Barcode
315	289	764	276044

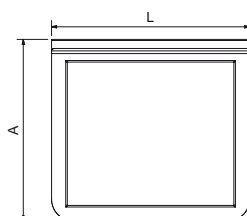

## Carro de recogida

Collection trolley  
Chariot de ramassage

### Características:

Diseñado para facilitar la recogida de vajilla, cubiertos y desperdicios.  
Estantes regulables en altura.  
Ruedas de 125 mm de diámetro.  
Alta resistencia.  
Posibilidad de añadir más estantes.  
Provisto de cubeta GN 1/2 de 200 mm. de profundidad y tova de desbarasado.

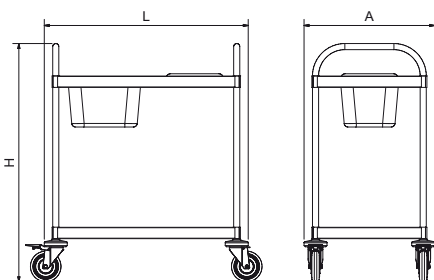

### Characteristics:

Specially designed for the collection of cutlery, plates and waste.  
Adjustable height.  
Wheels diameter 125 mm.  
Heavy duty.  
Optional levels if required.  
Provided with Gastronorm container 1/2-200 mm and waste chute.

### Caractéristiques:

Conçu pour la collecte des couverts, assiettes et déchets.  
Réglable en hauteur.  
Roues en diamètre 125 mm.  
Robuste.  
Niveaux supplémentaires optionnels.  
Fourni avec bac Gastro 1/2-200 mm et trémie vide-déchets.

Dimensiones Dimensions Dimensions				
L	A	H	Kg	Barcode
835	535	975	15,5	076020
1.035	535	975	16,5	076022
1.235	535	975	18,5	076024



## Repuestos para carros de servicio y recogida

Spare parts for service and collection trolleys

Pièces de rechange pour chariots de service et ramassage

		Descripción Description Description	
		Kg	
		Bastidor para carro de servicio Frame for service trolley Châssis pour chariot de service	1,8 276030
		Entrepaño para carro de servicio de 800x500 mm. Shelf for service trolley of 800x500 mm. Étagère pour chariot de service de 800x500 mm.	3,5 276050
		Entrepaño para carro de servicio de 1.000x500 mm. Shelf for service trolley of 1.000x500 mm. Étagère pour chariot de service de 1.000x500 mm.	4,5 276052
		Entrepaño para carro de servicio de 1.200x500 mm. Shelf for service trolley of 1.200x500 mm. Étagère pour chariot de service de 1.200x500 mm.	5,5 276054
		Rueda galvanizada con freno de diámetro 125 mm. Galvanized wheel of diameter 125 mm. with brake Roulette galvanisée avec frein diamètre 125 mm.	0,8 485010
		Rueda galvanizada sin freno de diámetro 125 mm. Galvanized wheel of diameter 125 mm. without brake Roulette galvanisée sans frein diamètre 125 mm.	0,7 485012
		Parachoques para carros de servicio Bumper for service trolleys Pare-chocs pour chariots de service	0,2 485050
		Kit de acoplamiento de rueda a bastidor de carros de servicio Wheel fixing kit for service trolleys frame Kit d'accouplement de roulette pour châssis de chariots de service	0,12 085014

## Carro para lavado con desagüe

Washing trolley with drain

Chariot à lavage avec écoulement

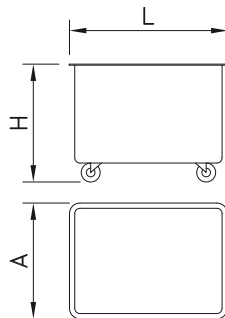

2 ruedas fijas y 2 giratorias de Ø 80 mm.

2 fixed wheels and 2 rotating wheels Ø 80 mm.

2 roues fixes et 2 roues tournantes Ø 80 mm.

### Dimensiones

Dimensions  
Dimensions

L	A	H	lit	Kg	
750	550	560	155	8,20	481070

## Carro para canales

Carcass trolley

Chariot à carcasses



**\*HASTA 500 Kg**  
Up to 500 kgs  
Jusqu'à 500 kgs

### Características:

4 ruedas giratorias.  
Estante inferior movable.  
Estructura del tubo 40x40 mm.

### Characteristics:

4 swivel wheels.  
Detachable lower level.  
Tube 40x40 mm.

### Caractéristiques:

4 roues pivotantes.  
Niveau inférieur amovible.  
Tube 40x40 mm.

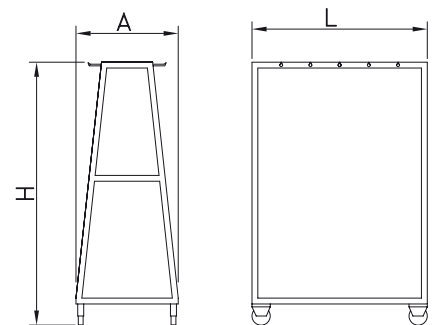

### Dimensiones

Dimensions  
Dimensions

L	A	H	Kg	
1.200	700	1.800	38	476030

## Carros Gastronorm

Gastronorm trolleys  
Chariots Gastronom

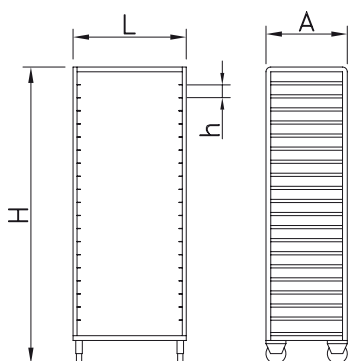

### Características:

4 ruedas giratorias, 2 de ellas con freno.

### Characteristics:

4 swivel wheels, 2 of them with brakes.

### Caractéristiques:

4 roues pivotantes, dont 2 avec freins.



### Dimensiones

Dimensions  
Dimensions

L	A	H	h	GN		Kg	
440	615	1.880	78	1/1	20	16	476020
645	725	1.880	78	2/1	20	21	476022

## Carro Euronorm

Euronorm tray trolley  
Chariot pour plateaux Euronorm

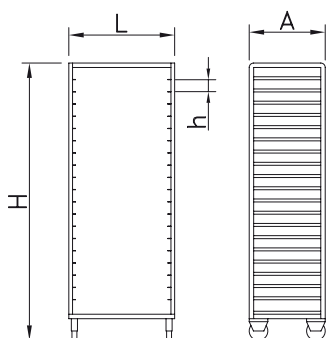

### Características:

4 ruedas giratorias, 2 de ellas con freno.

### Characteristics:

4 swivel wheels, 2 of them with brakes.

### Caractéristiques:

4 roues pivotantes, dont 2 avec freins.



### Dimensiones

Dimensions  
Dimensions

L	A	H	h		Kg	
625	460	1.800	78	20	19	476010

## Carro de transporte

Platform trolley  
Chariot à plate-forme

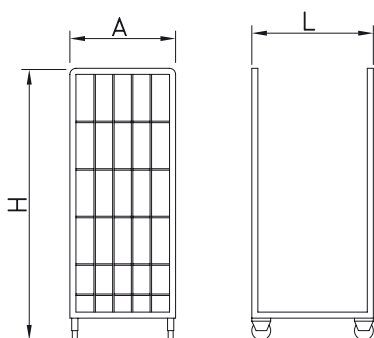

### Características:

Acabado en cincado electrofítico.  
2 ruedas giratorias y 2 fijas.

### Characteristics:

Electrolytic zinc finishing.  
2 swivel wheels and 2 fixes wheels.

### Caractéristiques:

Finition en zinc électrolytique.  
2 roues pivotantes et 2 roues fixes.



### Dimensiones

Dimensions  
Dimensions

L	A	H	Kg	Kg	
700	800	1.800	600	22	476002



## Mesas centrales encimera de polietileno

Centre tables with polyethylene worktop  
Tables centrales dessus en polyéthylène

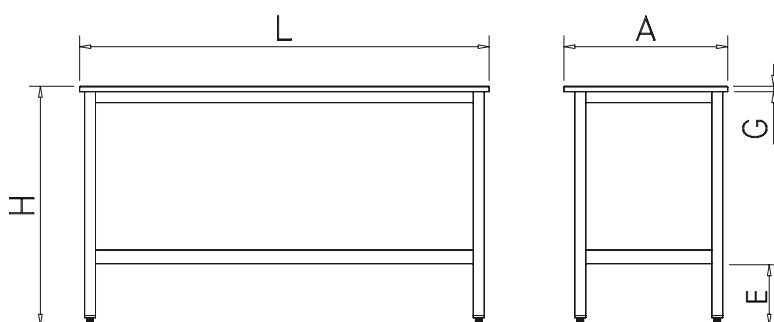

Dimensiones Dimensions Dimensions										
L	A	H	G	E	Kg		Kg		Kg	
1.000	500	870	20	200	22	071202 071252	19	071402 071452	5	270202
1.500	500	870	20	200	34	071204 071254	28	071404 071454	9	270204
2.000	500	870	20	200	46	071206 071256	35	071406 071456	14	270206
1.000	600	870	20	200	25	071208 071258	21	071408 071458	6	270208
1.500	600	870	20	200	37	071210 071260	30	071410 071460	10	270210
2.000	600	870	20	200	53	071212 071262	41	071412 071462	15	270212
1.000	700	870	20	200	28	071214 071264	22	071414 071464	8	270214
1.500	700	870	20	200	42	071216 071266	33	071416 071466	13	270216
2.000	700	870	20	200	57	071218 071268	44	071418 071468	19	270218



Repuestos de fibras.  
Spare fibres.  
Fibres de rechange.

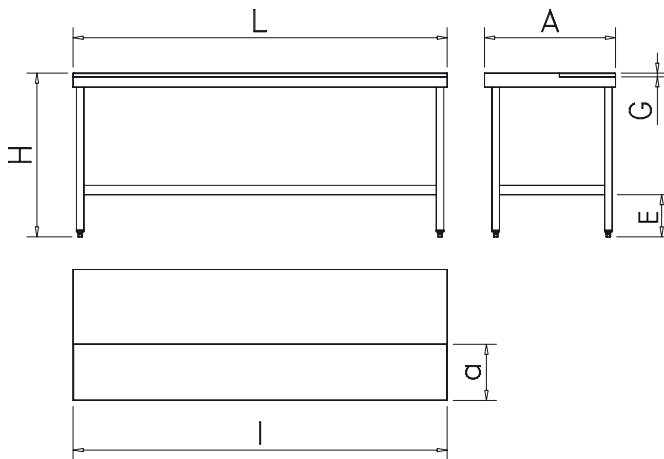

Dimensiones Dimensions Dimensions												
L	A	H	l	a	G	E	Kg		Kg		Kg	
1.000	600	850	1.000	300	20	200	37	071602 071652		071802 071852	6	270208
1.500	600	850	1.500	300	20	200	50	071604 071654		071804 071854	10	270210
2.000	600	850	2.000	300	20	200	66	071606 071656		071806 071856	15	270212
1.000	700	850	1.000	300	20	200	42	071608 071658		071808 071858	8	270214
1.500	700	850	1.500	300	20	200	56	071610 071660		071810 071860	13	270216
2.000	700	850	2.000	300	20	200	75	071612 071662		071812 071862	19	270218
1.000	800	850	1.000	300	20	200	47	071614 071664		071814 071864	10	270220
1.500	800	850	1.500	300	20	200	62	071616 071666		071816 071866	14	270222
2.000	800	850	2.000	300	20	200	82	071618 071668		071818 071868	21	270224



Repuestos de fibras.  
Spare fibres.  
Fibres de rechange.

78

## Mesas de preparación murales

Wall-side preparation tables

Tables de préparation murales

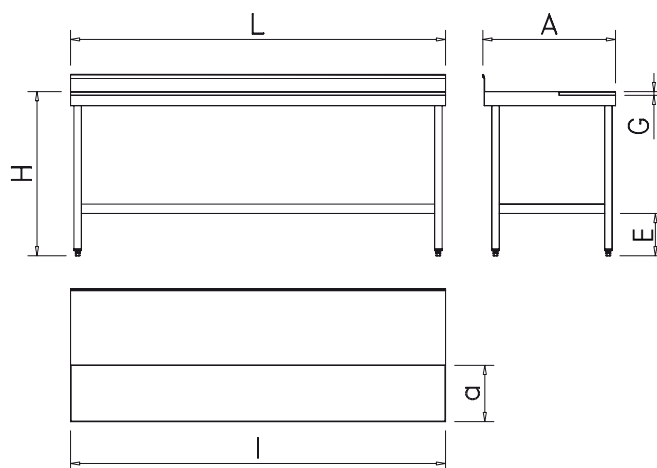

Dimensiones Dimensions Dimensions												
L	A	H	I	a	G	E	Kg		Kg		Kg	
1.000	600	850	1.000	300	20	200	37	072002 072052	33	072202 072252	6	270208
1.500	600	850	1.500	300	20	200	49	072004 072054	42	072204 072254	10	270210
2.000	600	850	2.000	300	20	200	64	072006 072056	52	072206 072256	15	270212
1.000	700	850	1.000	300	20	200	39	072008 072058	34	072208 072258	8	270214
1.500	700	850	1.500	300	20	200	54	072010 072060	46	072210 072260	12	270216
2.000	700	850	2.000	300	20	200	73	072012 072062	59	072212 072262	18	270218
1.000	800	850	1.000	300	20	200	44	072014 072064	36	072214 072264	10	270220
1.500	800	850	1.500	300	20	200	60	072016 072066	50	072216 072266	14	270222
2.000	800	850	2.000	300	20	200	78	072018 072068	62	072218 072268	21	270224



Repuestos de fibras.  
Spare fibres.  
Fibres de rechange.

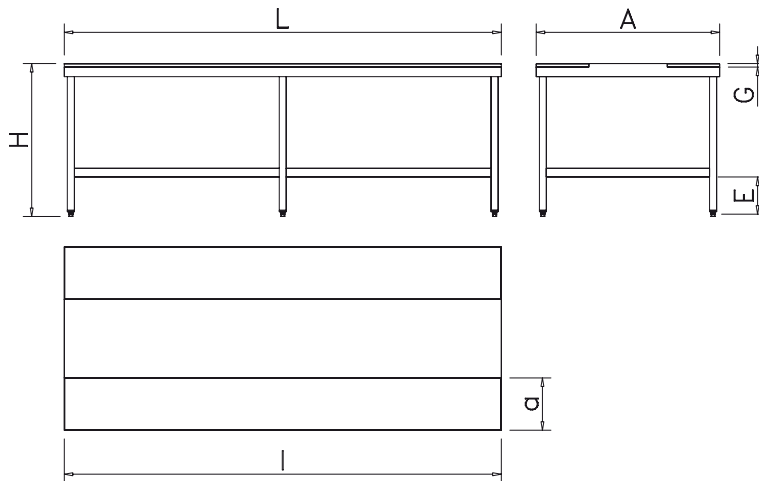

Dimensiones Dimensions Dimensions										
L	A	H	I	a	G	E	Kg	Kg	Kg	
1.500	1.050	850	1.500	400	20	200	78	65	20	
							072402	072602	270238	
							072452	072652		
2.000	1.050	850	2.000	400	20	200	105	86	27	
							072404	072604	270240	
							072454	072654		
2.500	1.050	850	2.500	400	20	200	132	108	30	
							072406	072606	270242	
							072456	072656		
3.000	1.050	850	3.000	400	20	200	158	128	39	
							072408	072608	270244	
							072458	072658		
1.500	1.300	850	1.500	400	20	200	91	73	25	
							072410	072610	270246	
							072460	072660		
2.000	1.300	850	2.000	400	20	200	125	97	32	
							072412	072612	270248	
							072462	072662		
2.500	1.300	850	2.500	400	20	200	160	115	58	
							072414	072614	270250	
							072464	072664		
3.000	1.300	850	3.000	400	20	200	185	132	62	
							072416	072616	270252	
							072466	072666		







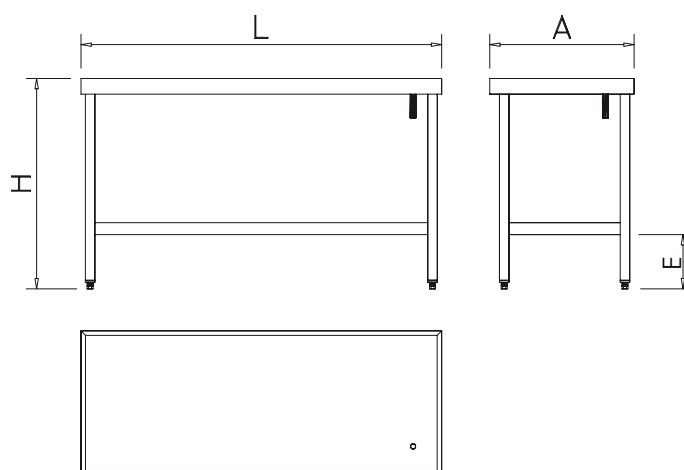

Repuestos de fibras.  
 Spare fibres.  
 Fibras de rechange.

## Mesas centrales con reborde y desagüe

Centre tables with raised edge and drain







Tables centrales avec rebord et trou d'écoulement

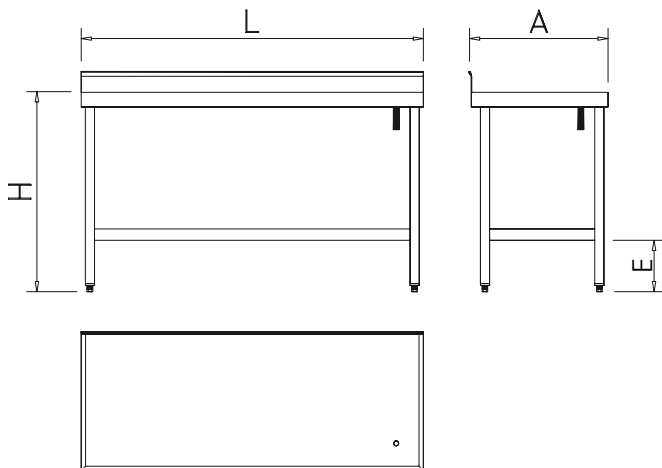

Dimensiones Dimensions Dimensions									
L	A	H	E	Kg		Kg		Kg	
1.000	800	850	200	38	073002	30	073202	10	270220
1.500	800	850	200	51	073004	40	073204	14	270222
2.000	800	850	200	67	073006	50	073206	21	270224
1.000	900	850	200	46	073008	38	073208	11	270226
1.500	900	850	200	54	073010	42	073210	15	270228
2.000	900	850	200	76	073012	55	073212	25	270230
1.000	1.000	850	200	49	073014	40	073214	12	270232
1.500	1.000	850	200	58	073016	45	073216	16	270234
2.000	1.000	850	200	81	073018	56	073218	26	270236

**Mesas murales con reborde y desagüe**  
 Wall-side tables with raised edge and drain  
 Tables murales avec rebord et trou d'écoulement



Dimensiones Dimensions Dimensions									
L	A	H	E	Kg		Kg		Kg	
1.000	600	850	200	30	073402	25	073602	6	270208
1.500	600	850	200	39	073404	32	073604	10	270210
2.000	600	850	200	51	073406	42	073606	15	270212
1.000	700	850	200	33	073408	28	073608	8	270214
1.500	700	850	200	46	073410	38	073610	12	270216
2.000	700	850	200	60	073412	46	073612	18	270218
1.000	800	850	200	36	073414	29	073614	10	270220
1.500	800	850	200	49	073416	39	073616	14	270222
2.000	800	850	200	65	073418	48	073618	21	270224
1.000	900	850	200	37	073420	32	073620	11	270226
1.500	900	850	200	50	073422	44	073622	15	270228
2.000	900	850	200	67	073424	52	073624	25	270230
1.000	1.000	850	200	40	073426	35	073626	12	270232
1.500	1.000	850	200	53	073428	48	073628	16	270234
2.000	1.000	850	200	71	073430	55	073630	26	270236



## Mostrador de pescadería con soporte

Floor-mounted fish counter  
Étal à poisson avec support

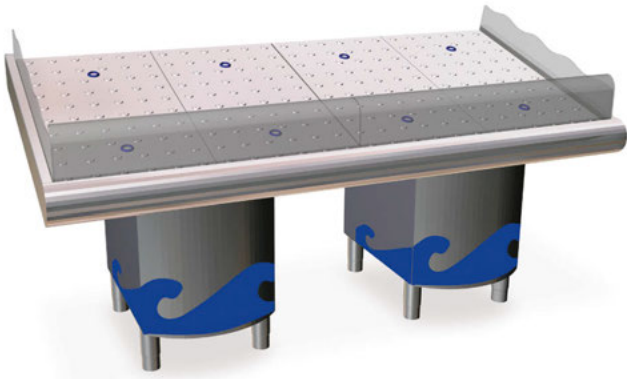

Tacos regulables  
Protector frontal curvado transparente  
Laterales transparentes  
Bandejas perforadas  
Desagües  
Conectores rápidos desagües  
Mangueras desagües  
Puertas desmontables  
Juego de adhesivos ola para los frentes

Adjustable blocks  
Front and sides in plastic  
Perforated trays  
Drainers  
Quick connectors hoses  
Drains hoses  
Rear detachable doors  
Set of decorative stickers "Ola"

Taquets réglables  
Front et flancs en plastique  
Plateaux perforés  
Déversoirs  
Connecteurs rapide pour tuyaus  
Tuyaus déversoirs  
Portes postérieures amovibles  
Jeu d'autocollants décoratives

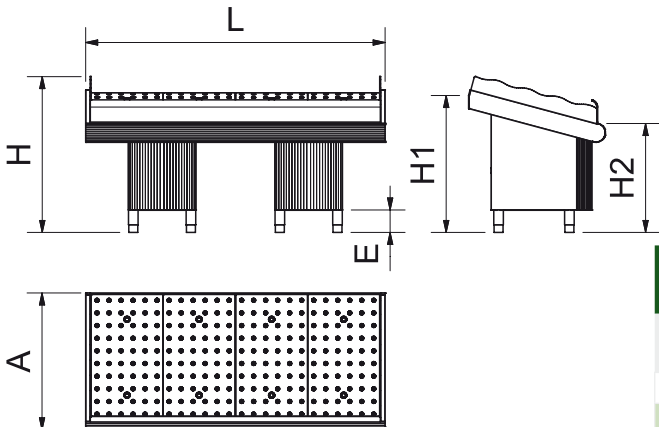
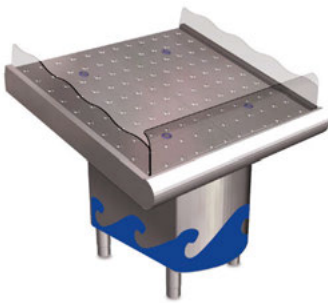

### Características:

Fabricado totalmente con acero inoxidable AISI 304, está diseñado para adaptarse a las necesidades de los diferentes establecimientos.

### Characteristics:

Wholly made of stainless steel AISI 304, it has been designed to meet the needs of any establishment.

### Caractéristiques:

Fabriqué totalement en acier inoxydable AISI 304, c'est conçu pour subvenir les besoins de tous les établissements.

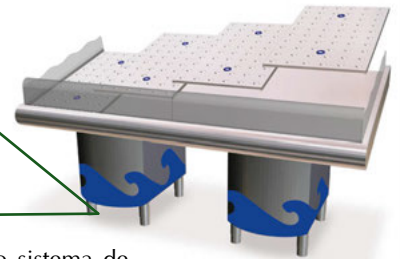
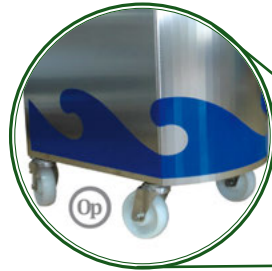

Mediante un novedoso sistema de bandejas conseguimos que el hielo permanezca sujeto a la exposición, evitando su desplazamiento hacia la parte delantera. A diferencia de otros expositores, con nuestro diseño ahorraremos energía y agua, pues con una capa menor de hielo conseguiremos exponer mejor el producto.

By means of a new trays system we achieve the ice to remain fixed to the counter and we avoid it to slide to the front side. Unlike other counters, with this new system we will save both water and energy, since with a thinner sheet of ice you will be able to exhibit your products in the best conditions.

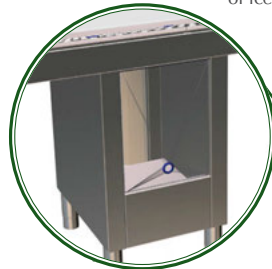

Mediante la regulación de los pies podemos incrementar la altura hasta 50 mm más.



By the adjustment of the legs you can increase the height up to 50 mm.

Par le réglage des pieds vous pouvez incrémenter l'hauteur jusqu'à 50 mm.

### Dimensiones

Dimensions

Dimensions

L	A	H	H1	H2	E		Kg	
985	950	1.045	960	730	150	1	51	074439
1.950	950	1.045	960	730	150	2	116	074440
2.912	950	1.045	960	730	150	2	120	074444

**Características:**

Fabricado totalmente con acero inoxidable AISI 304, está diseñado para adaptarse a las necesidades de los diferentes establecimientos.

**Characteristics:**

Wholly made of stainless steel AISI 304, it has been designed to meet the needs of any establishment.

**Caractéristiques:**

Fabriqué totalement en acier inoxydable AISI 304, c'est conçu pour subvenir les besoins de tous les établissements.

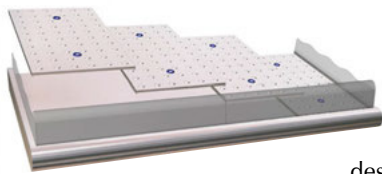
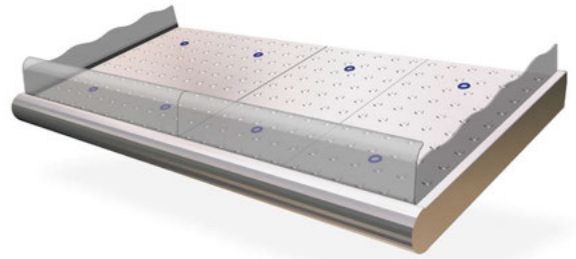

Mediante un novedoso sistema de bandejas conseguimos que el hielo permanezca sujeto a la exposición evitando su desplazamiento a la parte delantera.

A diferencia de otros expositores con nuestro diseño ahorraremos energía y agua pues con una capa menor de hielo conseguiremos exponer mejor el producto.

Protector frontal curvado transparente  
Laterales transparentes  
Bandejas perforadas pescaderías  
Desagües  
Mangueras desagües

By means of a new trays system we achieve the ice to remain fixed to the counter and we avoid it to slide to the front side. Unlike other counters, with this new system we will save both water and energy, since with a thinner sheet of ice you will be able to exhibit your products in the best conditions.

Front and sides in plastic  
Perforated trays  
Drainers  
Drains hoses

Front et flancs en plastique  
Plateaux perforés  
Déversoirs  
Tuyaux déversoirs

Grâce à un nouveau système de plateaux nous atteindrons que le glace reste fixe au comptoir et nous évitons qu'elle se glisse vers la partie inférieure. Contrairement à autres étals, avec ce système vous économiserez de l'eau et de l'énergie, puisque avec une couche de glace plus fine vous pourrez exposer vos produits dans les meilleures conditions.

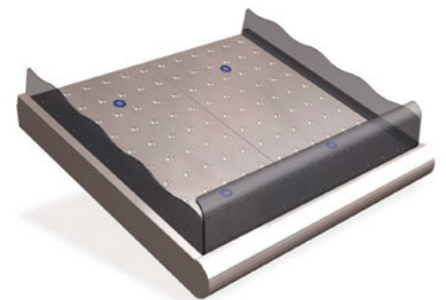

Dimensiones Dimensions Dimensions				
L	A	H	Kg	
985	950	270	25	074441
1.950	950	270	48	074442
2.912	950	270	70	074446

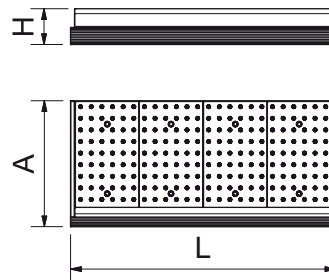

**Prolongación modular para mostrador de pescadería**

Modular extension for fish counter  
Extension modulaire pour étal à poisson



**Contenido:**  
Tacos regulables  
Laterales transparentes  
Dos bandejas perforadas

**Included:**  
Adjustable feet  
Transparent sides  
Two perforated trays

**Inclus:**  
Pieds réglables  
Côtés transparents  
Deux plateaux perforés

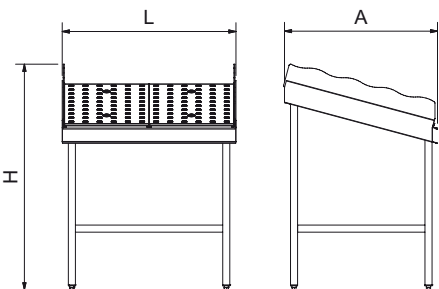
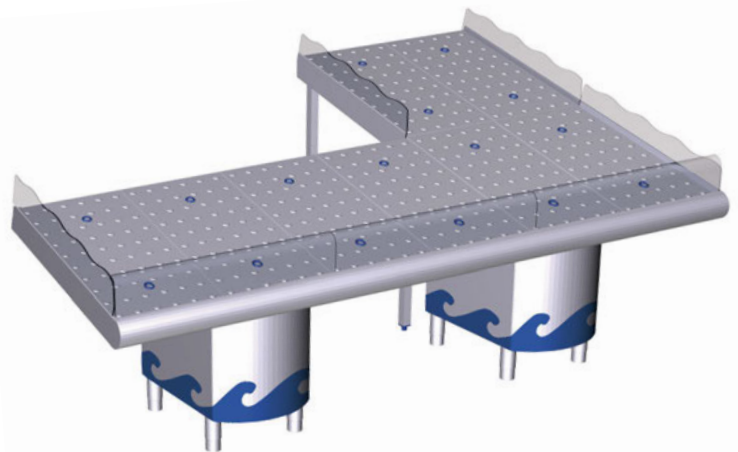

**Características:**

Con esta ampliación modular del mostrador podrá duplicar la zona de exposición en la zona que más le interese. Desmontable, movable y regulable en altura.

**Characteristics:**

This modular extension will allow you make double your display space at the required area. It is detachable, movable and with adjustable height.

**Caractéristiques:**

Cette extension modulaire vous permettra doubler votre espace d'exposition à la zone nécessaire. Elle est amovible, mobile et réglable en hauteur.

Dimensiones Dimensions Dimensions				
L	A	H	Kg	
985	867	1.279	29,5	074462



074444



3.700,00



240



Mostrador de pescadería con soporte  
Floor-mounted fish counter  
Étal à poisson avec support

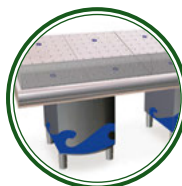

074462



1.155,00



241



Prolongación modular para mostrador de pescadería  
Modular extension for fish counter  
Extension modulaire pour étal à poisson

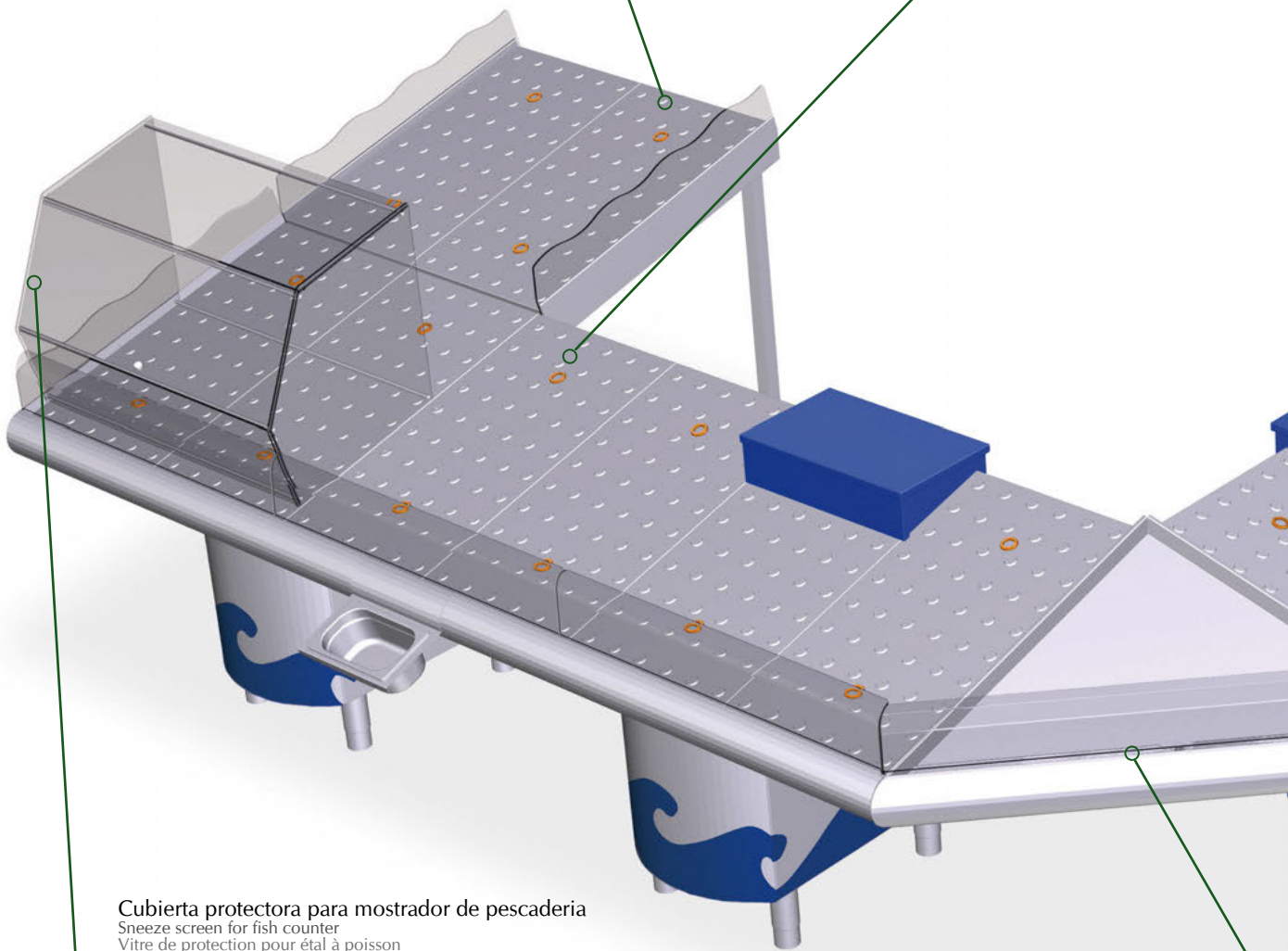
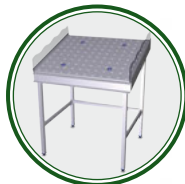

Cubierta protectora para mostrador de pescadería  
Sneeze screen for fish counter  
Vitre de protection pour étal à poisson

Dimensiones  
Dimensions  
Dimensions

L	A	H	Kg	Barcode
960	500	572	4,80	074464

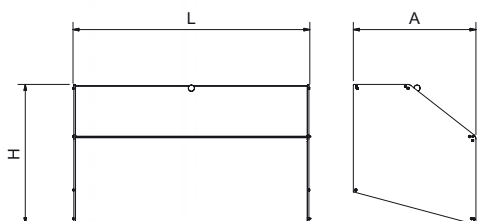



074460



244

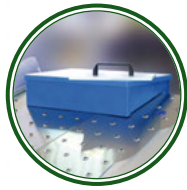

Tajo-expositor para mostrador de pescadería  
Polyethylene cutting board-display for fish counter  
Plaque de découpe-exposant en polyéthylène pour étal à poisson



Unión en escuadra interior para mostradores de pescadería  
Fish counter internal-corner link  
Jonction d'angle interne pour étal à poisson



Dimensiones  
Dimensions  
Dimensions

L	A	H	Kg	Barcode
1.230	870	118	8,00	074449

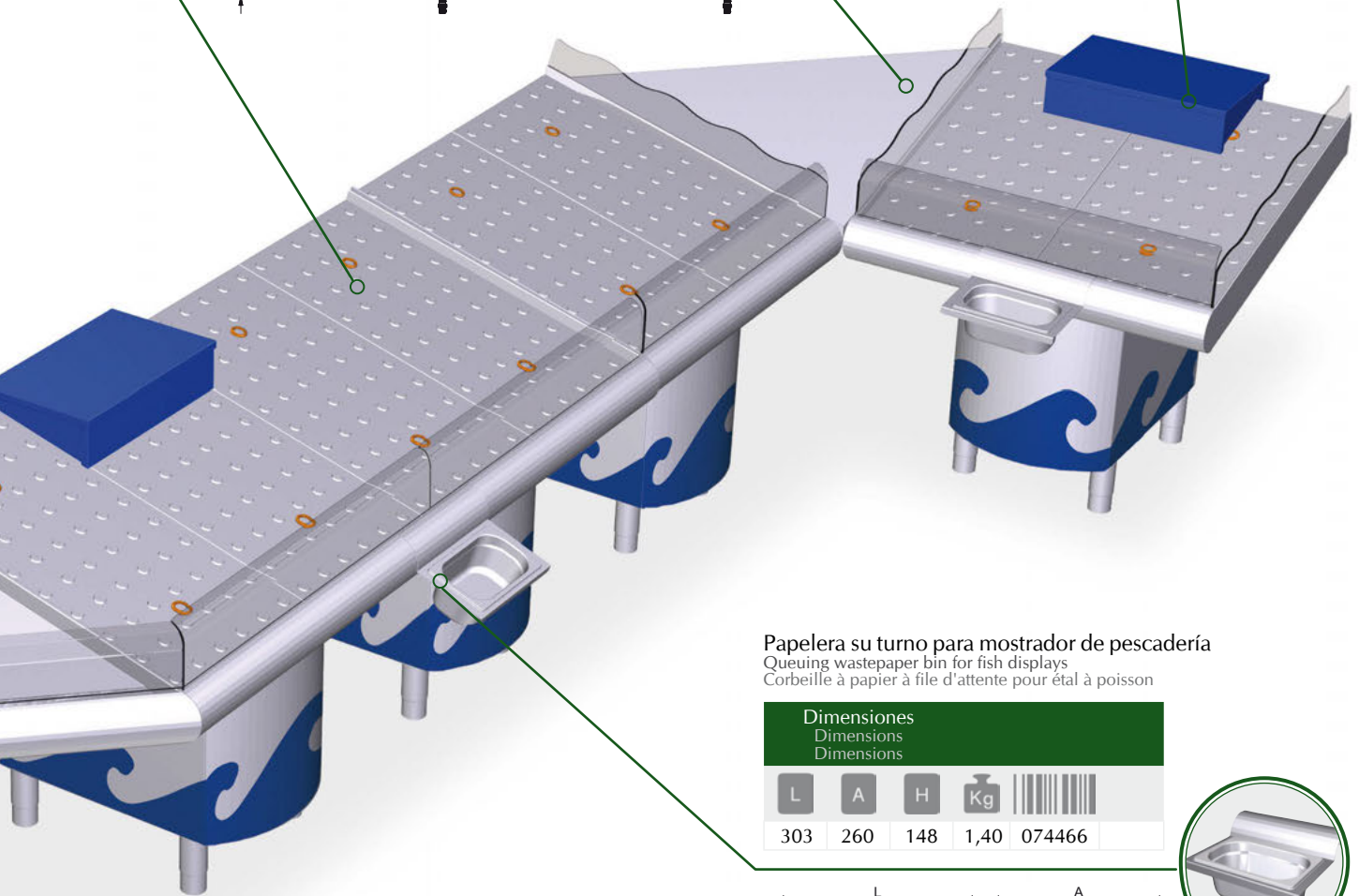
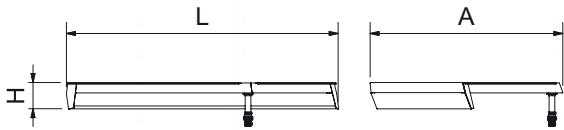

Papelera su turno para mostrador de pescadería  
Queuing wastepaper bin for fish displays  
Corbeille à papier à file d'attente pour étal à poisson

Dimensiones  
Dimensions  
Dimensions

L	A	H	Kg	Barcode
303	260	148	1,40	074466

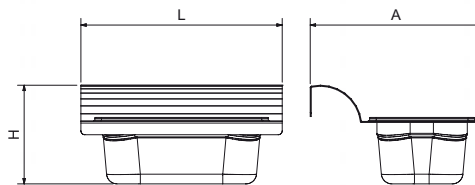

Unión en escuadra  
Fish counter corner link  
Jonction d'angle pour étal à poisson

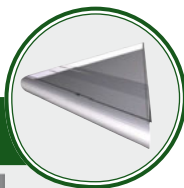

Dimensiones  
Dimensions  
Dimensions

L	A	H	Kg	Barcode
1.290	960	256	11,00	074448

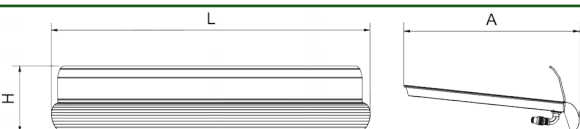



## Repuestos para mostradores de pescadería

Spares parts for fish counter

Rechanges pour étals à poisson

Descripción Description Description		Gr	
	<b>Frontal curvado transparente de 963 mm.</b> Curved transparent front panel 963 mm. Panel courbe transparent 963 mm.	550	274490
	<b>Lateral transparente</b> Transparent side panel Panel latéral	410	374460
	<b>Bandeja perforada para mostrador de pescadería</b> Perforated tray for fish counter Plateau perforé pour comptoir à poisson	3.000	274476
	<b>Pie regulable inox de Ø 63,5x150 mm.</b> Adjustable stainless foot ø63,5x150 mm. Pied réglable inoxydable ø63,5x150 mm.	200	409856
	<b>Adhesivo modelo "Ola"</b> "Wave" model sticker Autocollant modèle "vague"	80	474468
	<b>Desagüe de poliamida blanca 3/4" L=90 mm.</b> White polyamide drain 3/4" L=90 mm. Déversoir en polyamide 3/4" L=90 mm.	90	474460
	<b>Adaptador de 3/4" H para conector rápido</b> F 3/4" adaptor for quick connector Adaptateur 3/4" F pour connecteur rapide	60	474474
	<b>Conector rápido 3/4"</b> 3/4" Quick connector Connecteur rapide 3/4"	85	474476
	<b>Manguera flexible de 1"</b> Flexible hose 1" Tuyau flexible 1"		474478
	<b>Pasacable azul Ø 36x2,5 mm.</b> Blue passcable Ø 36x2,5 mm. Passecâble bleu Ø 36x2,5 mm.	0,006	409830

## Tajo-expositor para mostrador de pescadería

Polyethylene cutting board-display for fish counter

Plaque de découpe-exposant en polyéthylène pour étal à poisson

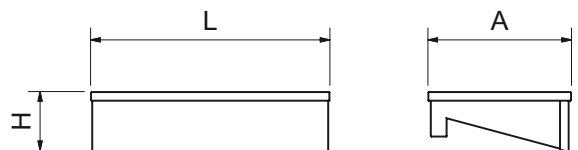
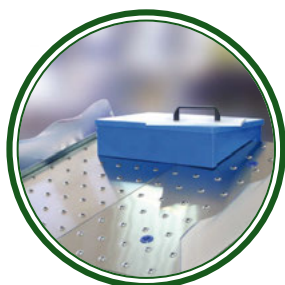

Dimensiones  
Dimensions  
Dimensions



500 300 125 4,70 074460

**Paleta de fibra para aplastar hielo**  
Polyethylene trowel for crushing ice  
Truelle en polyéthylène pour piler la glace

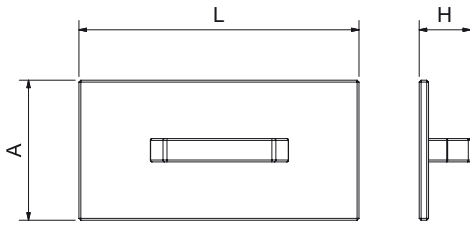

**Dimensiones**  
Dimensions  
Dimensions

L	A	H	Gr	Barcode
300	150	55	500	032202

**Características:**

Su fabricación en polipropileno garantiza:  
No absorbe agua.  
No pierde su dureza en condiciones de humedad.  
Puede ser esterilizado (no en autoclave).  
Soporta temperaturas de hasta 100°C.

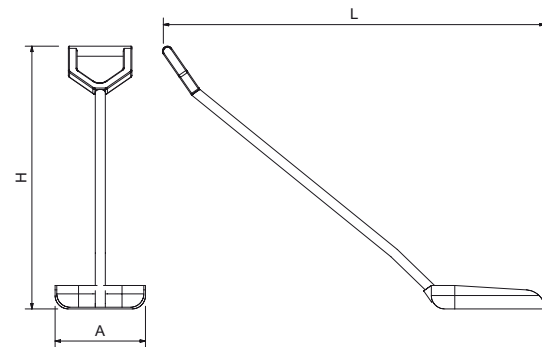

**Characteristics:**

It is made of polypropylene, which guarantees:  
No water absorption.  
No loss of hardness in humidity conditions.  
Possibility of sterilization.  
It resists temperatures up to 100°C.

**Caractéristiques:**

Sa fabrication en polypropylène garantit:  
Pas d'absorption d'eau.  
Pas de perte de dureté dans conditions d'humidité.  
Possibilité de stérilisation.  
Supporte température jusqu'à 100°C.



**Dimensiones**  
Dimensions  
Dimensions

L	A	H	Gr	Barcode
890	265	660	500	474458

**Características:**

Su fabricación en polipropileno garantiza:  
No absorbe agua.  
No pierde su dureza en condiciones de humedad.  
Puede ser esterilizado (no en autoclave).  
Soporta temperaturas de hasta 100°C.

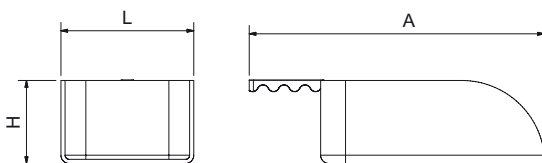

**Pala de mano para hielo**  
Ice shovel  
Pelle à glaçons



**Characteristics:**

It is made of polypropylene, which guarantees:  
No water absorption.  
No loss of hardness in humidity conditions.  
Possibility of sterilization.  
It resists temperatures up to 100°C.

**Caractéristiques:**

Sa fabrication en polypropylène garantit:  
Pas d'absorption d'eau.  
Pas de perte de dureté dans conditions d'humidité.  
Possibilité de stérilisation.  
Supporte température jusqu'à 100°C.

**Dimensiones**  
Dimensions  
Dimensions

L	A	H	Gr	Barcode
160	340	90	150	474456



## Mesas de preparación y lavado

Preparation and cleansing tables

Tables de préparation et de lavage



### Dotación y características de fabricación:

Totalmente construida con acero inoxidable.  
Fibra de polietileno calidad P-500.  
Fregadero soldado con válvula, tapón y rebosadero.  
Tolva de evacuación de desperdicios.

### Features and manufacturing characteristics:

Made totally from stainless steel.  
P-500 quality polyethylene fibre.  
Welded bowl with valve, plug and overflow.  
Hole for waste-chutes

### Dotation et caractéristiques de fabrication:

Entièrement fabriquées en acier inoxydable.  
Fibre de polyéthylène qualité P-500.  
Bac soudée avec valve, déversoir.  
Trou pour tremie à déchets.



**Posibilidad de fregadero a la derecha.**  
Possibility to place the sink on the right.  
Possibilité de placer le réservoir sur la droite.



**Repuestos de fibras.**  
Spare fibres.  
Fibres de rechange.



78

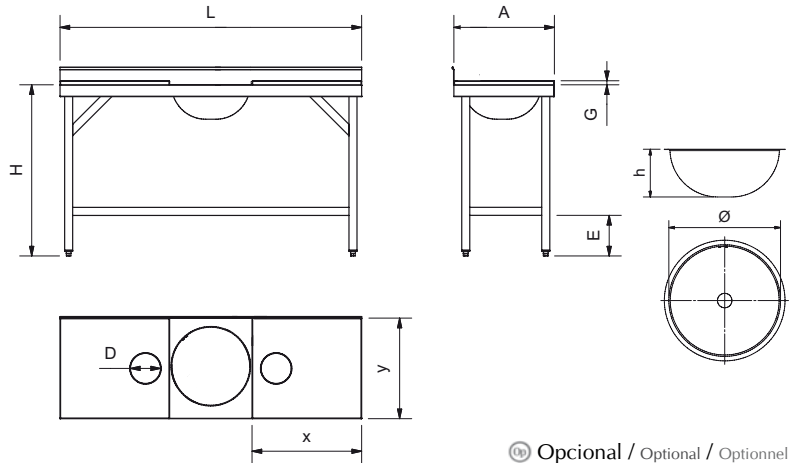

Ⓜ Opcional / Optional / Optionnel

### Dimensiones Dimensions Dimensions

	L	A	H	E	Ø	h	X	y	G	D	Kg	Barcode
	1.000	500	850	200	390	170	545	500	20	150	28	072802 072880 072852
	1.500	500	850	200	390	170	760	500	20	235	43	072812 072884 072862
	1.500	500	850	200	390	170	545	500	20	150	50	072822 072888 072872

**Puesto pescadero encimera polietileno**  
 Fish preparation table with polyethylene worktop  
 Table de préparation de poisson dessus en polyéthylène

**Características:**

Su peto trasero en plástico permite trabajar cómodamente de cara al público y evitar salpicaduras. El precio incluye el portacuchillos para adosar con envoltorio.

**Characteristics:**

Plastic back fringe that allows an agreeable work face to the public and to avoid splashing. Provided with mounted knife holder with wrapping.

**Caractéristiques:**

Pan coupé postérieur en plastique qui permet travailler commodément face au public et éviter des éclaboussures. Pourvu avec porte-couteaux pour adosser avec enveloppant.

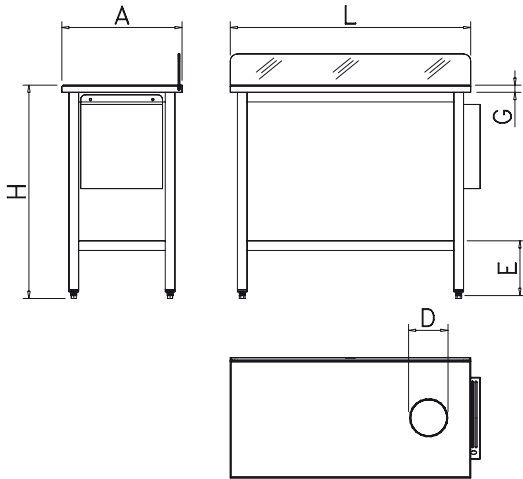

Dimensiones Dimensions Dimensions								
L	A	H	D	G	E	Kg	074424	
1.000	500	850	150	30	200	20		

Repuestos de fibras.  
 Spare fibres.  
 Fibras de rechange.

78

**Puesto pescadero modelo sencillo**  
 Fish preparation table simple model  
 Table de préparation de poisson modèle simple

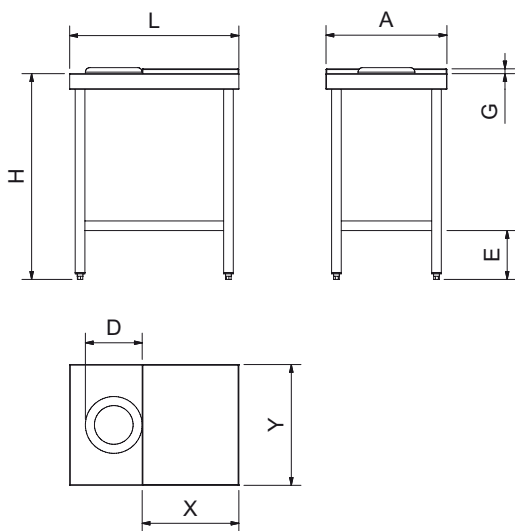

Dimensiones Dimensions Dimensions										
L	A	H	X	Y	D	G	E	Kg	074404	€
700	500	850	400	500	235	20	200	18	074407	
									074406	

Repuestos de fibras.  
 Spare fibres.  
 Fibras de rechange.

78

## Fregaderos soldados a mesas

Sink units welded to tables  
Evier soudés aux tables

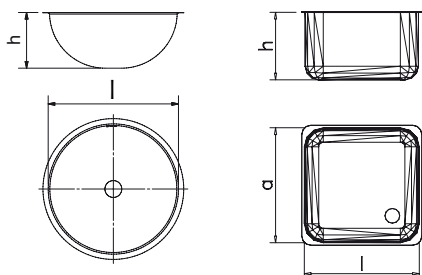
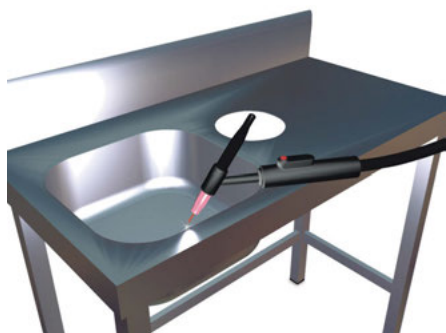

Dimensiones Dimensions Dimensions				
l	a	h		
260	Ø	115		057003
390	Ø	150		057005
400	400	250		057008
400	400	300		057010
500	500	300		057012
500	500	350		057014
600	450	300	•	057016
600	450	300	•	057017
600	450	350	•	057018
600	450	350	•	057019
600	500	300	•	057020
600	500	300	•	057021
600	500	350	•	057022
800	420	350	•	057024
800	420	350	•	057026
1.060	420	350	•	057028
1.060	420	350	•	057030

## Atril con cajón

Desk with drawer  
Pupitre avec tiroir

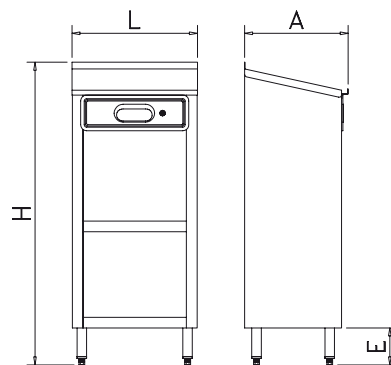

Cajón con cerradura.  
Lock drawer.  
Tiroir avec serrure.

Dimensiones Dimensions Dimensions				
L	A	H	E	Kg
443	436	1.230	200	43

**Características:**

Construida totalmente en acero inoxidable, acabado satinado. Dispone de techo inclinado y patas en altura de 115 mm para poder limpiar debajo de ella. Estas patas están situadas de manera que salvan la curva sanitaria en la pared. Pies regulables. Ventilación mediante respiraderos embutidos. Cerraduras independientes. Cada cuerpo lleva un entrepaño superior, otro en la base y un perchero.



**Characteristics:**

Totally made in stainless steel, satin finished, they have inclined roof, legs' high 115 mm. To be able to clean under them, also these legs are situated to save the sanitary curve in walls, regulable feet, ventilation by inlay breathings, and individual locks. Every section has a lower and an upper shelf and a clothes rack.

**Caractéristiques:**

Fait totalement en acier inox, finition satiné, ils ont le toit incliné, pieds en hauteur de 115 mm. Pour pouvoir nettoyer par dessous d'eux, aussi ces pieds sont situés pour qu'ils sauvent la courbe sanitaire dans le mur, pieds réglables, ventilation par soupirlais encastrés, et fermeture indépendante. Chaque section a un évier supérieur et inférieur et un portemanteau.



€ 45,00 255 Op

**Cerradura de retorno de monedas**  
 Coin operated lock  
 Serrure à monnaies



481402 3,00 255 Op

**Llave maestra para cerraduras.**  
 Master key for locks  
 Clé passe-partout pour serrures

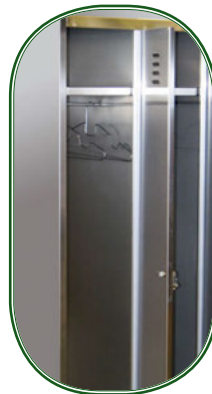
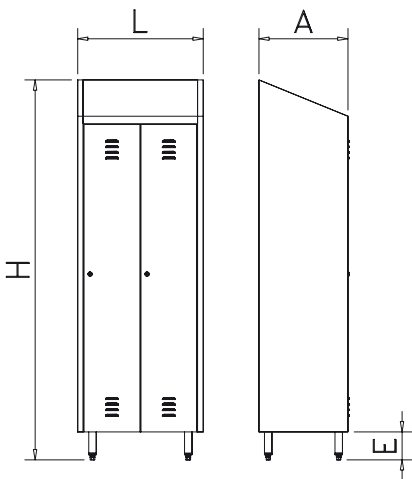

**Posibilidad de acoplar ruedas ver pág 353**  
 Possibility of assembly wheels, see page 353  
 Possibilité d'accoupler rouelles, voir page 353

**Dimensiones**  
 Dimensions  
 Dimensions

L	A	H	E		Kg	
370	480	2.010	115	1	27	081412
680	480	2.010	115	2	49	081406
985	480	2.010	115	3	62	081408



**Contienen dos perchas inox por puerta.**  
 Two inox hangers for each door included.  
 Deux cintres inox inclus par chaque porte.



**Consulten la posibilidad de acoplar un desinfectador-desodorizador por ozono en las taquillas.**  
 Ask for the possibility of assembly a disinfectant-deodorant by ozone in the locker.  
 Demandez-nous sur la possibilité de accoupler un désinfectant-désodorisant à l'ozone dans l'armoire.

## Taquillas de 2, 4 y 6 puertas

2, 4 and 6 doors lockers

Armoire pour vestiaire de 2, 4 et 6 portes

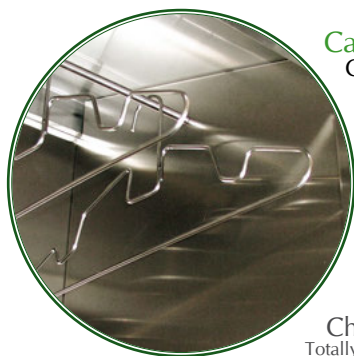

### Características:

Construida totalmente en acero inoxidable, acabado satinado. Dispone de techo inclinado y patas en altura de 115 mm para poder limpiar debajo de ella. Estas patas están situadas de manera que salvan la curva sanitaria en la pared. Pies regulables. Ventilación mediante respiraderos embutidos. Cerraduras independientes. Cada cuerpo lleva un entrepaño superior, otro en la base y un perchero.

### Characteristics:

Totally made in stainless steel, satin finished, they have inclined roof, legs' high 115 mm. To be able to clean under them, also these legs are situated to save the sanitary curve in walls, regulable feet, ventilation by inlay breathings, and individual locks. Every section has a lower and an upper shelf and a clothes rack.

### Caractéristiques:

Fait totalement en acier inox, finition satiné, ils ont le toit incliné, pieds en hauteur de 115 mm. Pour pouvoir nettoyer par dessous d'eux, aussi ces pieds sont situés pour qu'ils sauvent la courbe sanitaire dans le mur, pieds réglables, ventilation par soupiraux encastrés, et fermeture indépendante. Chaque section a un évier supérieur et inférieur et un portemanteau.



€ 45,00 255 Op

Cerradura de retorno de monedas  
Coin operated lock  
Serrure à monnaies



481402 € 3,00 255 Op

Llave maestra para cerraduras.  
Master key for locks  
Clé passe-partout pour serrures

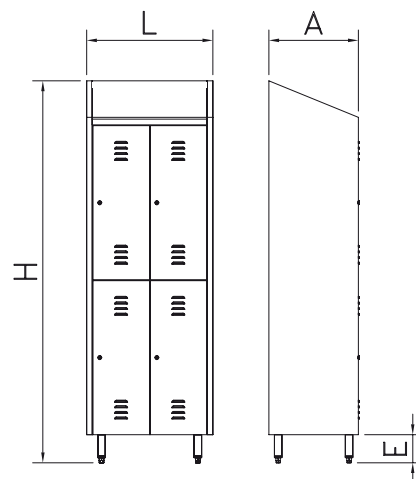

Contienen dos perchas inox por puerta.  
Two inox hangers for each door included.  
Deux cintres inox inclus par chaque porte.



Posibilidad de acoplar ruedas ver pág 353  
Possibility of assembly wheels, see page 353  
Possibilité d'accoupler rouelles, voir page 353

### Dimensiones

Dimensions  
Dimensions

L	A	H	E		Kg	
370	480	2.010	115	2	28	081410
680	480	2.010	115	4	50	081402
985	480	2.010	115	6	68	081404



Consulten la posibilidad de acoplar un desinfectador-desodorizador por ozono en las taquillas.  
Ask for the possibility of assembly a disinfectant-deodorizant by ozone in the locker.  
Demandez-nous sur la possibilité de accoupler un désinfectant-désodorisant à l'ozone dans l'armoire.

## Percha industrial de acero inoxidable

Stainless steel industrial hanger  
Cintre industrielle en acier inoxydable

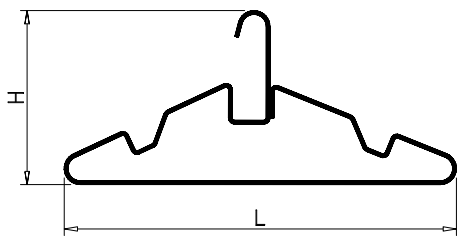

### Características:

Totalmente construida en acero inoxidable.  
Ideal para gimnasios, piscinas, vestuarios colectivos, lavanderías, etc.  
Diseño renovado que permite colgar delantales y prendas con tirantes.



### Characteristics:

Wholly made of stainless steel.  
Excellent for gymnasiums, swimming pools, dressing-rooms, laundries, etc.  
New design that allows to hang up aprons and garments with shoulder straps.

### Caractéristiques:

Entièrement construit en acier inoxydable.  
Excellente pour gymnases, piscines, établissements de bains, blanchisseries, etc.  
Dessin renouvelé qui permet prendre des tabliers et vêtements à épaulettes.

### Dimensiones

Dimensions

Dimensions

L

H

Gr



420

190

120

081450

### Características:

Estructura de acero inoxidable.  
Asiento de fenólico en laminas color azul.

Cantos redondeados.  
Tornillos ocultos en inoxidable.

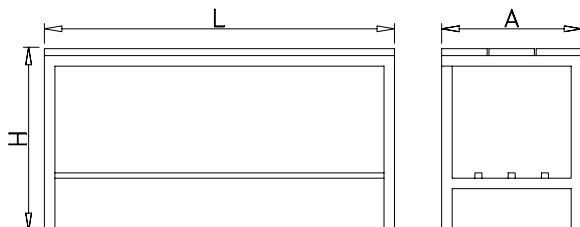

## Banco vestuario

Changing room bench  
Banc pour vestiaire

### Dimensiones

Dimensions

Dimensions

L

A

H

Kg



1.000

340

480

12,0

481602

1.500

340

480

18,0

481604

### Characteristics:

Structure manufactured in stainless steel.  
Seat of phenol lames of blue colour.  
Rounded edge.  
Hidden screws in stainless steel.

### Caractéristiques:

Structure construit en acier inoxydable.  
Siège en phénol de lames couleur bleu.  
Rebord ronde.  
Vis occultes en acier inoxydable.

## Separadores para taquillas

Dividers for lockers  
Diviseur pour armoire vestiaire

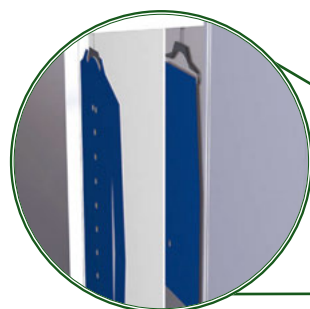
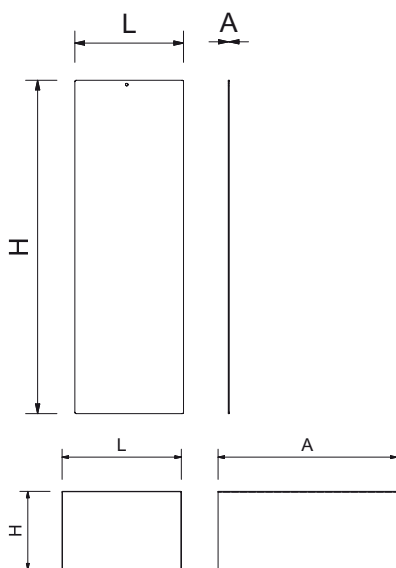

081456

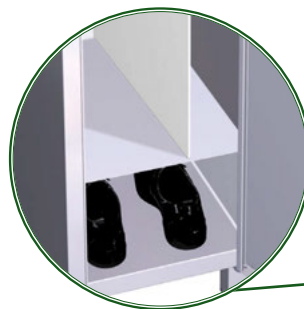

081458

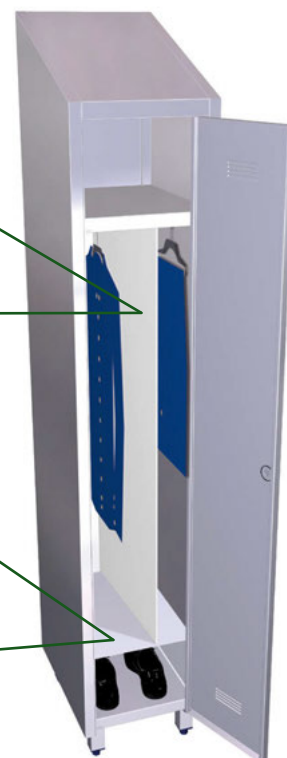

### Dimensiones

Dimensions

Dimensions

L

A

H

Kg



450

3

1.180

0,80

081456

300

450

197

2,03

081458



## Armario para productos de limpieza

Wardrobe for cleaning products

Armoire pour produits d'entretien



### Características:

Como dotación estándar lleva tres estantes en el lado derecho para la colocación de trapos, productos de limpieza, etc. Además, su diseño permite guardar cubos, recipientes grandes, escobas, fregonas, etc. Construido totalmente en acero inoxidable, acabado satinado, dispone de techo inclinado y 4 patas en altura de 115 mm para poder limpiar debajo de él. Estas patas están situadas de tal manera que salvan la curva sanitaria en la pared. Pies regulables. Ventilación mediante respiraderos embutidos. Pomo con posibilidad de acoplar candado. Ver página 256.



Set colgador sujeta-palos.  
Handle-holder kit.  
Kit porte-manches.

340

Opcional / Optional / Optionnel



### Characteristics:

As standard equipment it has three shelves within one side for the placing of clothes, cleaning products, etc. At the same time its design allows to put in buckets, big containers, brooms, mops, etc. Made totally in stainless steel, satin finished, posses reclined roof, legs of 115 mm height in order you can clean below. In addition, these legs are designed in such a way that saves the sanitary wall curve and at the same time they are adjustable. Ventilation by means of hammered vents and lock. A padlock can be placed onto the handle, see page 256.

### Caractéristiques:

Comme équipement standard il a trois étagères dans une des côtes pour la placement des chiffons, produit d'entretien, etc. En plus, sa dessine permet garder seaux, récipients grands, balais, balais-serpillières, etc. Construit totalement en acier inoxydable, avec finition satiné, ils ont toit penché et empiétements de 115 mm d'hauf pour qu'on peut nettoyer dessous. Ces empiétements sont dessinées tellement qui sauvent la courbe sanitaire du mur et en même temps sont réglables. Aération par soupiraux emboutis et serrure. On peut placer un cadenas dans le bouton, voir page 256.

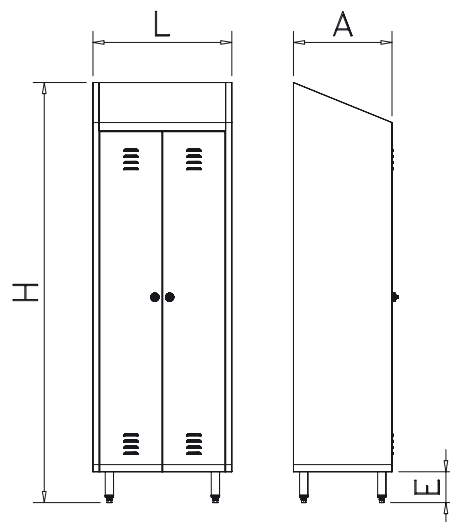

### Dimensiones

Dimensions

Dimensions

L	A	H	E		Kg	
370	480	2.010	115	1	27	081412
680	480	2.010	115	2	45	081602



Consulten la posibilidad de acoplar un desinfectador-desodorizador por ozono en el armario.

Ask for the possibility of assembly a disinfectant-deodorizant by ozone in the wardrobe  
Demandez-nous sur la possibilité de accoupler un désinfectant-désodorisant à l'ozone dans l'armoire

Posibilidad de acoplar ruedas ver pág 353

Possibility of assembly wheels, see page 353

Possibilité d'accoupler rouelles, voir page 353

**Armario estantería 2 puertas**  
2 doors shelving wardrobe  
Armoire rayonnage de 2 portes

**Características:**

Construido totalmente en acero inoxidable, acabado satinado, dispone de techo inclinado y 4 patas en altura de 115 mm para poder limpiar debajo de él. Estas patas están situadas de tal manera que salvan la curva sanitaria en la pared. Pies regulables. Ventilación mediante respiraderos embutidos. Pomo con posibilidad de colocar candado. Ver página 256.



**Characteristics:**

Made totally in stainless steel, satin finished, posses reclined roof, legs of 115 mm height in order you can clean below. In addition, these legs are designed in such a way that saves the sanitary wall curve and at the same time they are adjustable. Ventilation by means of hammered vents and lock. A padlock can be placed onto the handle, see page 256.

**Caractéristiques:**

Construit totalement en acier inoxydable, avec finition satiné, ils ont toit penché et empiétements de 115 mm d' haut pour qu' on peut nettoyer dessous. Ces empiétements sont dessinées tellement qui sauvent la courbe sanitaire du mur et en même temps sont réglables. Aération par soupiraux emboutis et serrure. On peut placer un cadenas dans le bouton, voir page 256.



**\*HASTA 190 Kg**  
Up to 190 kgs of load strength  
Jusqu' à 190 kgs de résistance



**\*HASTA 500 Kg**  
Up to 500 kgs of load strength  
Jusqu' à 500 kgs de résistance

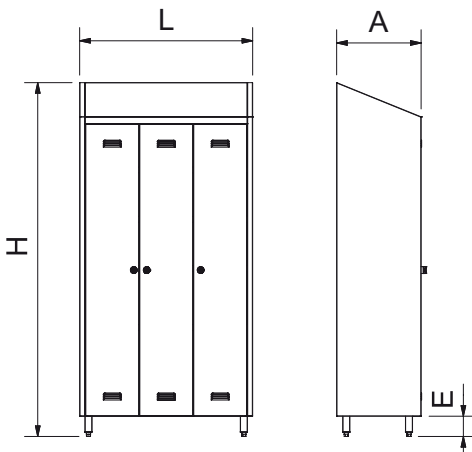

El pomo admite la colocación de candado.  
Handle-holder kit.  
Kit porte-manches.

256

Opcional / Optional / Optionnel



**Dimensiones**  
Dimensions  
Dimensions

L	A	H	E				
680	480	2.010	115	2	190	55	081650
980	480	2.010	115	3	500	66	081652



Posibilidad de acoplar ruedas ver pág 353  
Possibility of assembly wheels, see page 353  
Possibilité d' accoupler rouelles, voir page 353

## Armario para equipos informáticos

Wardrobe for computer equipment  
Cabinet pour matériel informatique

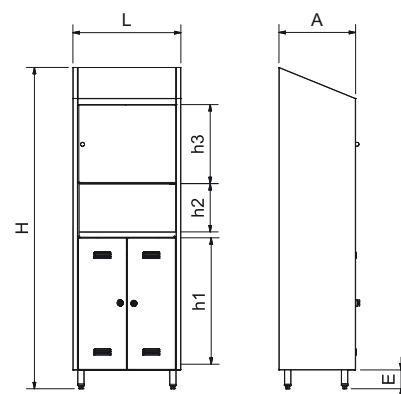

Dimensiones  
Dimensions  
Dimensions

L	A	H	E	h1	h2	h3	Kg	Barcode
680	480	2.010	115	795	300	500	52	076402

## Consigna para carros con taquilla

Left-trolleys with locker  
Consigne pour caddies avec casier

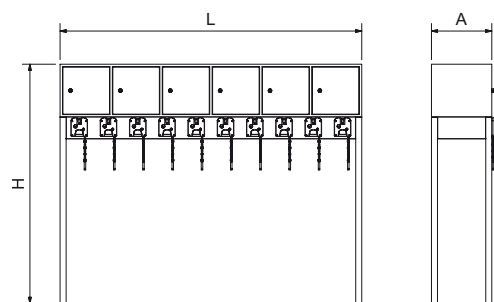
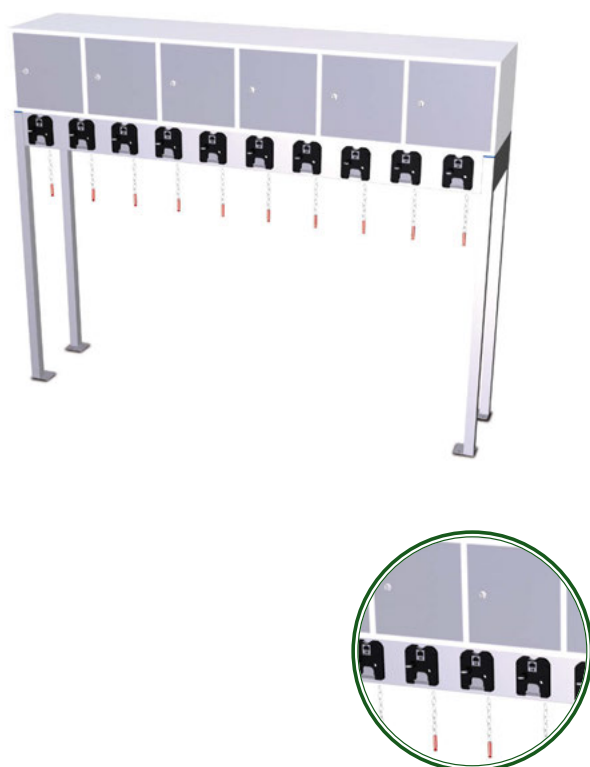

Dimensiones  
Dimensions  
Dimensions

L	A	H	Kg	Barcode
2.000	400	1.590	40	081432

## Consigna para carros

Left-shopping trolleys  
Consigne pour caddies

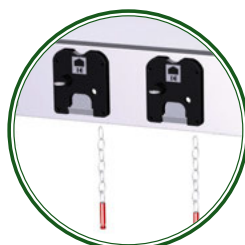
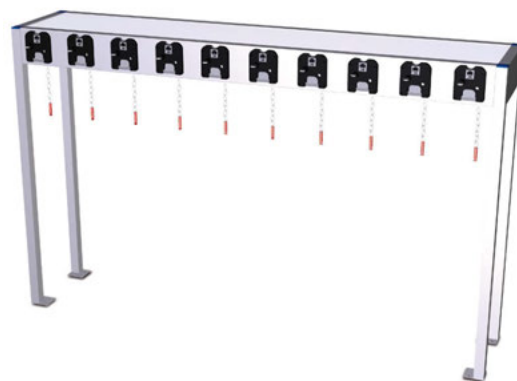
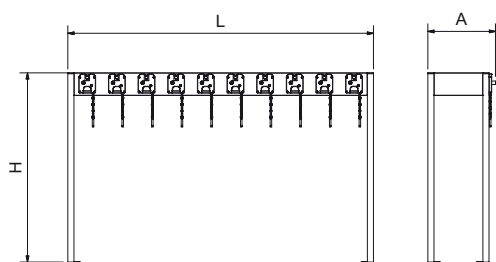

### Dimensiones

Dimensions  
Dimensions

L	A	H	Kg	
2.000	400	1.240	24	081430

## Taquilla - Consigna

Left-shopping - Lockers  
Casiers - Consigne

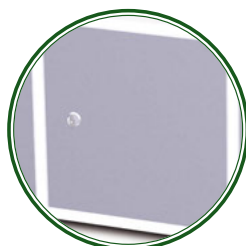
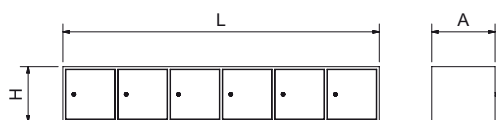

### Dimensiones

Dimensions  
Dimensions

L	A	H	Kg	
2.000	400	350	16	481436

## Repuestos y complementos

Spare part and complements  
Rechange et compléments



**N**ovedad  
ew  
ouveau

Descripción Description Description	Gr	
Cerradura Lock Serrure	41	481404
Cerradura maestra Master lock Serrure master		481405
Llave maestra para cerraduras Master key for locks Clé passe-partout pour serrures	10	481402
Cerradura de retorno de monedas Coin operated lock Serrure à monnaies	790	481410 481412
Montaje de la cerradura de retorno de monedas (no incluye cerradura) Assembly coin operated lock (lock not included in this price) Assembler serrure à monnaies (serrure n'inclus pas dans ce prix)		081452

## Repuestos y complementos

Spare part and complements

Rechange et compléments

Descripción Descripción Description		Gr	Barcode	
	<b>Pomo articulado</b> Articulated handle Poignée articulée	80	481406	
	<b>Candado para pomo articulado</b> Padlock for articulated handle Cadenas poignée articulée	105	481408	
	<b>Juego de herrajes para puertas (para 2 puertas)</b> Sliding doors fixtures set (valid for two doors) Set de ferrures pour portes coulissantes (valide pour deux portes)	85	073850	
	<b>Taco regulable</b> Adjustable blocks Taquets réglables	45	409851	
	<b>Taco regulable altura especial</b> Special height adjustable blocks Taquets réglables hauteur spéciale	115	409848	
	<b>Tirador para puerta abatible</b> Handle for hinged door Poignet pour porte battante	80	474050	
	<b>Cierre de clip de bolas</b> Roller bracket closing Fermeture à rouleau	40	474052	
	<b>Llavero numerado</b> Numbered key chain Porte-clés numérotés	30	481438	
	<b>Placa numerada</b> Numbered plate Plaque numérotée	20	481439	
	<b>Cerradura con cadena para consigna de carros</b> Locker with chain for left-shopping trolleys Serrure avec chaîne pour consigne pour caddies	850	481430	



Empresa Homologada por la  
Dirección General del Patrimonio del Estado

---

[mobiliar@mobiliar.es](mailto:mobiliar@mobiliar.es)  
[www.mobiliar.es](http://www.mobiliar.es)  
902 365 064



#### **CENTRAL**

C/ La Fragua, 5 • Edificio Mobiliar • Pl. "Los Rosales"  
Tel.: 916 656 230 • Fax: 916 641 506  
28933 Móstoles (Madrid)

#### **DELEGACIÓN**

C/ Pere el Ceremonios, 3 • Nave 2 • Pl. "Masía de Espí"  
Tel.: 961 534 064 • Fax: 961 537 790  
46930 Quart de Poblet (Valencia)

#### **FÁBRICA**

Avda. de las Retamas, s/n • Pl. "Monte Boyal"  
Tel.: 918 171 744 • Fax: 918 170 952  
45950 Casarrubios del Monte (Toledo)